

Conex | Bänninger

# Conex Compression



## Conex Compression Technical Brochure

## Contents

1.0	General .....	1
1.1	Quality and certification	
1.2	Product design	
1.3	Materials	
1.4	Threaded connections	
1.5	Tube compatibility	
1.6	Storage and handling	
1.7	COSHH (Control of Substances Hazardous to Health)	
1.8	Finish availability	
1.9	Conversion data for connecting metric fittings to imperial tube	
2.0	Applications .....	3
3.0	Product Suitability .....	4
3.0.1	Drinking water installations	
3.0.2	Heating and cooling systems	
3.0.3	Local and district heating	
3.0.4	Thermal solar system	
3.1	Thermal Expansion .....	4
3.1.1	Effects of expansion	
3.1.2	Expansion devices	
3.2	Corrosion Resistance .....	5
3.2.1	Stress corrosion cracking	
3.2.2	Corrosion on copper and copper alloys	
3.3	Pressure Testing .....	6
3.4	System Commissioning .....	7
3.4.1	Flushing of water installations	
3.4.2	Water softening	
4.0	Jointing Instructions .....	8
4.1	Sizes 6 - 54 mm	
4.2	Minimum distances and insertion depths	
4.3	Threaded joints for water applications	
4.4	Connecting to plastic pipes	
4.5	Flange fittings – sizes 67 to 108 mm	
4.6	Internal reducers	
4.7	Jointing instructions for gas applications	
5.0	Other Installations .....	12
5.1	Solar installations	
5.2	Gas installations	
6.0	Operating Parameters .....	13
6.1	Operating temperature and pressures with metal tubes	
6.2	Operating temperatures and pressures with plastic pipe.	
7.0	Loss Coefficients .....	14
8.0	The Range .....	16
9.0	Guarantee .....	42

## 1.0 General

Conex Compression fittings are manufactured from high quality brass materials which ensures a permanently tight and secure connection, without the use of special tooling or additional sealant. These fittings are suitable for connecting a wide range of tubes, including copper tubes in accordance with EN 1057, carbon steel to EN 10305, stainless steel to EN 10312 and plastic pipes to BS 7291, EN 15875 and EN 15876.

### 1.1 Quality and certification

Conex Bänninger has 110 years of experience in manufacturing innovative products and operates an accredited Quality Managements System to ISO 9001.

Conex Compression fittings are tested and approved for use with drinking water up to 108 mm and for gas applications up to 28 mm. Tested and certified by independent European certification bodies such as WRAS (Water Regulations Advisory Scheme) confirming their suitability and reliability for drinking water use.

Conex Compression fittings are approved for various applications and certified by the following bodies:

Table 1:

Certificates and approvals	
WRAS	UK
BSI Kitemark	UK
DVGW	Germany
DNV	Germany
Bureau Veritas	Germany
KIWA water	Netherlands
KIWA Gas	Netherlands
KIWA SE Swedcert	Sweden
SVGW	Switzerland
ARGB-KVGB	Belgium
PZH	Poland
TYSK	Ukraine
PCT	Russia

### 1.2 Product design

Conex Compression fittings are designed to minimise flow restriction. They are designed with a symmetrical compression ring which provides a seal within the cone of the fitting and capnut providing a two point seal on the tube. The simple principle of a Conex Compression joint is shown sectioned in figure 1.

Conex Compression fittings are manufactured in accordance with EN 1254 and consist of the following components:

- Fitting body with machined tube stop
- Compression ring (olive)
- Capnut

Conex Compression hex nuts and unique ribbed pattern capnuts are supplied in sizes 6 mm to 28 mm fittings.

Sizes 35 mm, 42 mm and 54 mm are supplied with octagonal capnuts.

Sizes 66.7 mm, 76.1 mm and 108 mm sizes incorporate loose compression plates, tightened by six 3/8" BSW nuts.

Figure 1

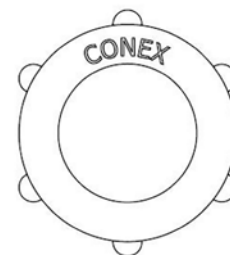
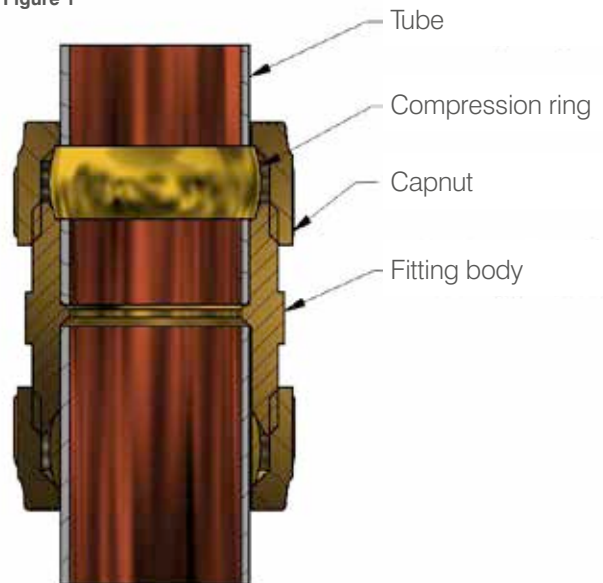

Unique rib nut profile

## 1.3 Materials

Conex Compression fittings are available in yellow brass, dezincification resistant brass and red brass (gunmetal). Components in contact with water are manufactured from low lead materials complying with the European requirements for materials in contact with drinking water.

### Low lead specification

- Standard material: EN 12165, CW 617N-DW
- DZR material: EN 12165, CW 511L
- Red brass (gunmetal): EN 1982, CC 499K

These materials meet the requirements of the 'UBA/4MS list of hygienically suitable materials for drinking water', and are ideal for all types of drinking water systems without restriction.

## 1.4 Threaded connections

Conex Compression fittings are available with male and female threaded connections. These threaded ends incorporate a hexagon or octagon nut for tightening the joint. They are manufactured to the following standards:

- Female threads to ISO 228 parallel.
- Male threads are either ISO 228 parallel or ISO 7 taper and EN10226..
- ISO 228 parallel threads require a sealing washer to affect the seal on the mating faces of the joint. Please note: these must not be used in gas installations.
- ISO 7 taper and EN10226 threads are sealed on the thread form with appropriate sealing material. Suitable for gas applications up to 1".
- The use of HEMP is not permitted.

## 1.5 Tube compatibility

Conex Compression connectors can be combined with:

- Copper tubes in accordance with EN 1057 up to 108 mm in R220 (liner required), R250 and R290 temper condition.
- Stainless steel tubes up to 28 mm in accordance with EN 10312, series 1 or 2.
- Carbon steel tubes up to 28 mm in accordance with EN 10305.
- Polybutylene (PB) to BS 7291 part 2 & EN 15876 up to 28 mm (liner required).
- PE-X pipe to BS 7291 part 3 and EN 15875 up to 28 mm (liner required).

For more details please see section 6.0 Operating Parameters.

## 1.6 Storage and handling

It is advisable to leave the fittings in the packaging to protect the fitting prior to installation. Please store in a cool dry place to protect the fittings from contamination, damage and dirt.

Cone face connectors to EN 1254-2 (BS 864: Part 2) rely on a metal to metal seal and care should be taken to avoid damage prior to assembly.

## 1.7 COSHH (Control of substances hazardous to health)

It is the responsibility of the end user to ensure that adequate protection is available where required and the necessary information regarding possible health and safety regulations is adhered to. Copper and copper alloy fittings are considered non-hazardous under normal circumstances.

## 1.8 Finish availability

Apart from the natural brass finish, Conex Compression fittings are also available in nickel or chrome plated finish in accordance with EN 248.

**Note:** It is recommended that you contact our customer service team for availability of any of our Conex Compression fittings in the plated versions.

## 1.9 Conversion data for connecting metric fittings to imperial tube to BS 659

Table 2:

Conversion table		
Metric size (mm)	Imperial size (")	Method of adaptation
12	3/8	Compatible – no adaptor required
15	1/2	Compatible – no adaptor required
22	3/4	Exchange existing 22 mm 65 compression ring for a 3/4" 65 compression ring (04-1020065--)
28	1	Exchange existing 28 mm 65 compression ring for a 1" 65 compression ring (05-1020065--)
35	1-1/4	Exchange existing 35 mm 65 compression ring for a 1-1/4" 65 compression ring (06-1020065--)
42	1-1/2	Exchange existing 42 mm 65 compression ring for a 42 x 1-1/2" S68S adaptor ring ( K071020068S-)
54	2	Compatible – no adaptor required
67	2-1/2	Compatible – no adaptor required
76.1	3	No adaptation possible a 76 x 3" 301IM coupler (R302020301IM) must be used.
108	4	Exchange existing 108 mm 65 compression ring for a 108 x 4" S68S adaptor ring (S405020068S-)

## 2.0 Applications

Table 3:

Applications	Flow medium	Tube type				
		Copper	Stainless steel	Carbon steel	PB	PE-X
Drinking water applications EN 806	Drinking water	√	√	x	√	√
Sealed heating systems to EN12828	Heating water	√	√	√	√	√
Open vented heating systems	Heating systems	√	√	x	√	√
Solar thermal systems EN 12975 / 12976	Water and water-glycol mixtures mixing ratio max. 50/50%	√	x	x	x	x
Chilled water *	Water and water-glycol mixtures. mixing ratio max. 50/50%	√	√	x	x	x
Rainwater harvesting systems	Rainwater from cisterns	√	√	x	√	√
'Wet' fire extinguishing tube systems 14462	Firefighting water	√	√	√	x	x
Compressed air	Compressed air of all classes according to ISO 8573-1	√	√	√	x	x
Industrial and processing water	Reclaimed water 6.5 ≤ Ph 6.5 ≤ 9.5	√	√	√	x	x
Natural gas installations EN 1775 up to 28 mm**	Combustion gases	√	x	x	x	x
Liquefied petroleum gas installations up to 28 mm***	Combustion gases	√	x	x	x	x
Fuel oil supply systems	Heating oil EL	√	x	x	x	x

\* Please refer to the stress corrosion cracking, section 1.5.

\*\* Up to 28 mm only.

\*\*\* Technology can only be surface mounted for this application.

For plastics, PE-X and PB pipes, please refer to the pipe manufacturer for applications and service conditions.

## 3.0 Product Suitability

The applications and tube type referred to in Table 3, must be adhered to when using and connecting Conex compression Brass and Copper Alloy fittings.

### 3.0.1 Drinking water installations

Drinking water installations must be planned and installed in accordance with local and national water byelaws and regulations and standards such as EN 806. Conex compression fittings have several accreditations for use with drinking water systems. For drinking water applications it is important to select the correct materials, EN 806 specifies requirements for drinking water applications that must be adhered to. Conex Compression fittings are made from materials that fully comply with European drinking water requirements. Conex Compression is also certified by Bureau Veritas for marine usage Ref. cert number . SMS.W.11./62847/D.0 and must be used within the range of recognition of NR320.

### 3.0.2 Heating and cooling systems

In closed heating, cooling and chilled water systems, there is generally an absence of oxygen which greatly reduces the likelihood of corrosion. This means a range of metallic materials may be used without the risk of corrosion; flow direction does not need to be taken into consideration.

Consequently, Conex Compression copper and copper alloy water fittings can be combined with other materials in a closed oxygen free system (reference EN 14868:2005).

Whilst, oxygen entry cannot always be fully prevented in extensive tube systems. EN 806 part 2 and 4 provide instructions for the measures to be taken in this case (chemical oxygen binding).

In the case of open vented systems, appropriate precautions should be taken with mixed metals to avoid any bi-metallic corrosion issues. You must ensure copper is installed downstream from galvanized steel components.

### 3.0.3 Local and district heating

Conex Compression can be used on local district heating systems within the operating parameters as per table 7.

### 3.0.4 Thermal solar system

Conex Compression fittings have been tested at ERA Technology Ltd. Surrey, for use in solar installations up to 200 °C at 10 bar using 50/50 glycol/water.

## 3.1 Thermal Expansion

### 3.1.1 Effects of expansion

The coefficient of linear expansion for copper is  $16.8 \times 10^{-6} \text{ } ^\circ\text{C}$ . For example, a 10 m length of copper tube, irrespective of its size, wall thickness or temper, will increase in length by 10.8 mm temperature rise of 60 °C. Tubes installed on hot water services must be free to accommodate this expansion; otherwise stresses will build up in the pipework that may lead to joints being pulled apart and/or tubes fracturing. Clearly the magnitude and frequency of such changes in length will determine the life of the joint or failure of the tube.

The table on page 5 shows the amount of tube expansion for a given temperature rise. In the case of tube in domestic hot water and heating installations the limited size of rooms and hence straight tube runs, together with the many bends and offsets that normally occur, will result in thermal movement being accommodated automatically. However, where long straight tube runs, exceeding 10 m, are encountered, allowance for expansion should be made.

A quick, economic and effective way of accommodating thermal expansion is to simply incorporate the horseshoe or compensating bend to the system design.

### 3.1.2 Expansion devices

Where copper tubes pass through walls, floors and ceilings, they should be able to move as a result of expansion and contraction. This can be arranged by passing the tube through a sleeve or length of larger diameter tube fixed through the whole thickness of the wall, floor, ceiling, or by means of flexible joints on either side of the wall.

Short stubs to and from radiators, connected to relatively long straight runs should also be avoided. This can usually be achieved by introducing an expansion loop, thereby increasing the length of pipework fixed between the flow/return legs and the radiator connection. However, expansion accommodation techniques such as the use of loops and horseshoes may not be sufficient to accommodate large expansions and in such cases the use of the bellows type couplers may be necessary.

Thermal expansion (mm) of copper tube as a function of tube length and temperature difference.

The table below shows the increase in length due to thermal expansion as a function of change in temperature  $\Delta t$  and the length of the tube at the lower temperature, irrespective of temper or wall thickness.

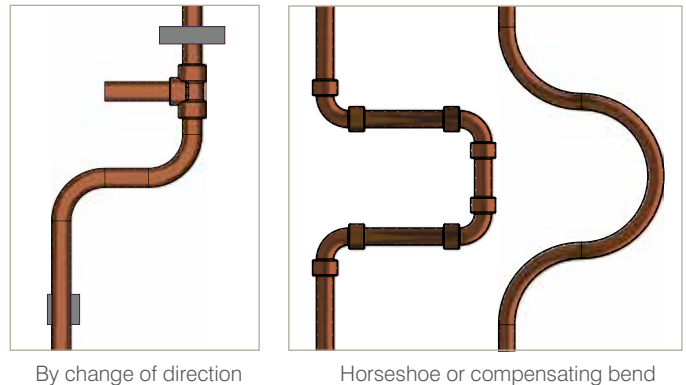

Table 4:

Tube length m	Change in length mm with temperature difference $\Delta t$ °C							
	$\Delta t=30^\circ$	$\Delta t=40^\circ$	$\Delta t=50^\circ$	$\Delta t=60^\circ$	$\Delta t=70^\circ$	$\Delta t=80^\circ$	$\Delta t=90^\circ$	$\Delta t=100^\circ$
0.1	0.05	0.07	0.08	0.10	0.12	0.13	0.15	0.17
0.2	0.10	0.13	0.17	0.20	0.24	0.27	0.30	0.34
0.3	0.15	0.20	0.25	0.30	0.35	0.40	0.45	0.50
0.4	0.20	0.27	0.34	0.40	0.47	0.54	0.60	0.67
0.5	0.25	0.34	0.42	0.50	0.59	0.67	0.76	0.84
0.6	0.30	0.40	0.50	0.60	0.71	0.81	0.91	1.01
0.7	0.35	0.47	0.59	0.71	0.82	0.94	1.06	1.18
0.8	0.40	0.54	0.67	0.81	0.94	1.08	1.21	1.34
0.9	0.45	0.60	0.76	0.91	1.06	1.21	1.36	1.51
1.0	0.50	0.67	0.84	1.01	1.18	1.34	1.51	1.68
2.0	1.01	1.34	1.68	2.02	2.35	2.69	3.02	3.36
3.0	1.51	2.02	2.52	3.02	3.53	4.03	4.54	5.04
4.0	2.02	2.69	3.36	4.03	4.70	5.40	6.05	6.72
5.0	2.52	3.36	4.20	5.04	5.88	6.72	7.56	8.40
10.0	5.04	6.72	8.40	10.80	11.76	13.44	15.12	16.80
15.0	7.56	10.80	12.60	15.12	17.64	20.16	22.68	25.20
20.0	10.08	13.44	16.80	20.16	23.52	26.88	30.24	33.60
25.0	12.60	16.80	21.00	25.20	29.40	33.60	37.80	42.00

$\Delta t$  dimensional increase is stated in mm

## 3.2 Corrosion Resistance

### 3.2.1 Stress corrosion cracking

In certain environments, particularly those containing corrosive media, stress corrosion cracking of yellow brass and DZR compression fittings can occur. It is important to

select the correct product for the application and to follow installation procedure to avoid corrosion or failure. For further information please visit [www.conexbanninger.com](http://www.conexbanninger.com).

### 3.2.2 Corrosion on copper and copper alloys

Regulations require that all water services (except warning or overflow pipes) shall be protected from freezing temperatures and heat gain. This is best achieved by protecting the system by use of a suitable thickness of insulation or in the case of particular situations such as unheated roof spaces that require special care, a self regulating trace heating tape.

Pipework may need to be protected from external corrosion causing construction materials, corrosive environments or abrasion. A variety of solutions are available, ducting, insulation, corrosion resistant paint finishes and anti-abrasive tape, the most effective solution should be chosen.

Systems containing copper tube with copper and copper alloy fittings generally have a high resistance to internal corrosion. However, it is recommended when systems have been hydrostatically pressure tested and are not going into immediate service, they are fully drained down and blown out with dry air. Alternatively, if this is impracticable, the system should be left 'wet', and flushed at regular intervals prior to being commissioned to reduce carbon film cold water pitting and the potential for legionella in stagnant water.

Precautions against freezing must also be undertaken. This is particularly important in new build housing when properties are not occupied for extended periods. For heating and cooling applications, Conex Compression fittings can be used with glycol-water mixtures up to a mixing ratio of 50:50 without affecting the product quality and the sealing element.

If a frost protection inhibitor is to remain in the pipelines permanently, at least one concentration test must be carried out annually. All chemical additions must be agreed before use to rule out negative interactions with materials and sealing elements. For more information, please contact Conex Bänninger technical department.

If commercial leak detector aerosols are used to detect leaks, it is recommended the residue is washed off with clean, warm water.

## 3.3 Pressure Testing

Pressure testing on Conex Compression fittings should normally be carried out using clean potable water. Only in exceptional circumstances should pneumatic pressure testing using compressed inert gas or air be used, and then only under careful controlled conditions.

Pressure testing should be carried out in accordance with national regulations, appropriate specifications should be drawn up and a risk assessment must be completed prior to testing.

Typically, when testing systems containing Conex Compression fittings, all joints shall remain uncovered and visible, the system shall be filled with clean potable water against an open high point valve allowing all trapped air to be removed from the network. Once free of trapped air, the high-level valve should be closed and the system topped up. At that stage testing can be completed between 1 to 2 bar and a full inspection made to ensure any leaking joints

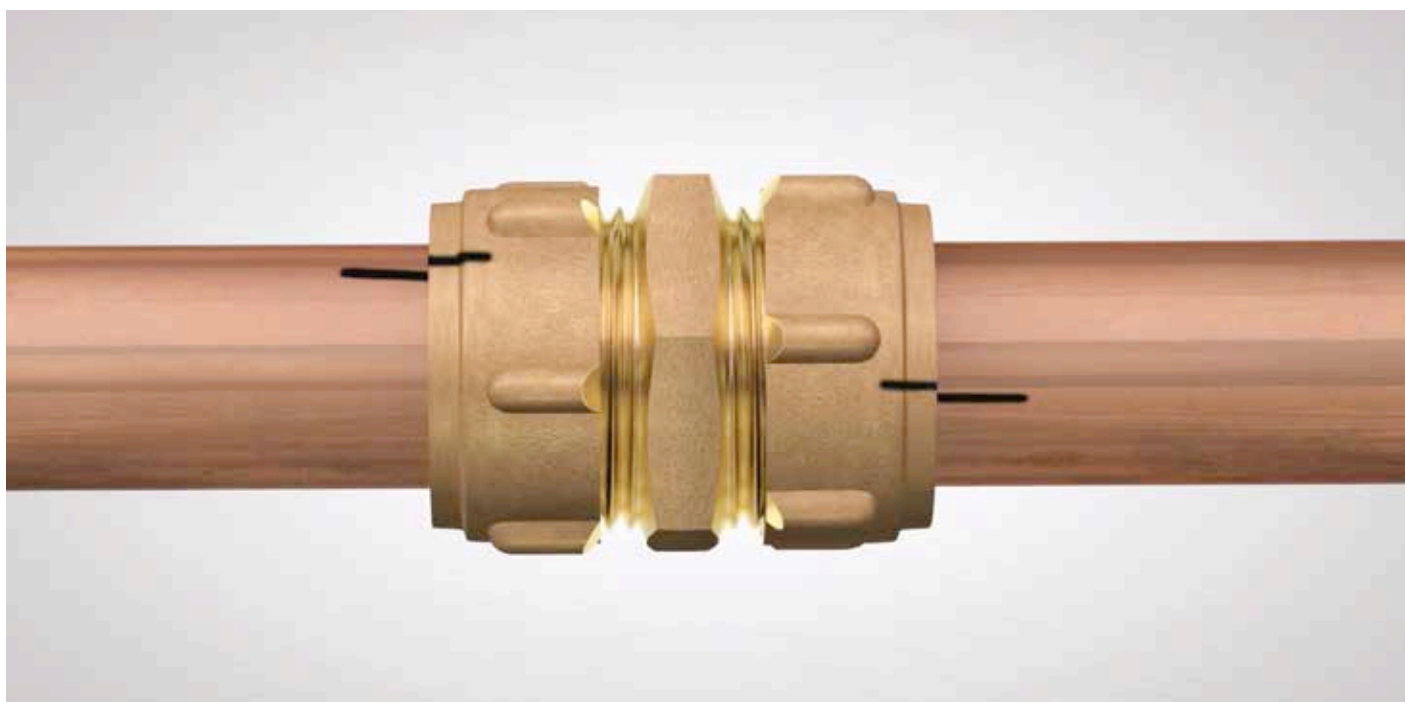

are identified. Any identified joints that have not been sealed and are leaking water can be tightened without draining down, however it is essential the tube is fully inserted. An additional 1/4 turned is viable.

Once it is confirmed there are no leaking joints, the pressure can be slowly raised to the system test pressure. The recommended system test pressure should be in accordance with the requirements of EN 806 part 4 (1.1 x maximum design pressure). Full test pressure should be maintained for a minimum of 30 minutes without any sign of pressure drop. A full inspection should then be carried out to identify any leaks.

## 3.4 System Commissioning

To ensure the quality and safety of hot and cold-water supply systems always follow best practice techniques in their design, installation, commissioning, and maintenance. A reliable and predictive regime of commissioning that does not have any detrimental effect on the longevity of the system should be in place as required by national, regional and local laws and regulations.

The chemicals used in the pre-commissioning, if incorrectly administered can have a serious effect on the systems' life, therefore the choice of chemicals is dependent on the particular site conditions, the materials used and the method(s) of construction.

Where a temporary mains supply(s) is to be used it should be cleaned and chlorinated in accordance with national regulations before being used for system filling and flushing.

For more information on chlorination, please refer to document 'pre-commissioning of systems' available at [www.conexbanninger.com](http://www.conexbanninger.com).

**Note:** Commercial anti-corrosion chemicals must not to be used on potable water systems.

### 3.4.1 Flushing of water installations

It is essential to flush the systems with water after installation to remove dust, debris and flux residues. Please note in the absence of national guidelines commissioning should be carried out in accordance with EN 806-4.

If installations are not used immediately after commissioning they should be flushed at regular intervals, at least once a week. After an extended time, it would be recommended the system is disinfected to comply with legionella guidelines.

### 3.4.2 Water softening

Hard water may be softened to avoid excessive deposits of scale in hot water services. However, a degree of scale is necessary to form the protective patina on copper tube. When a new copper tube installation has a water softener fitted from day one, it is good practice to run the system for approximately three months with the softener by-pass open to allow untreated water into the system, and allow the patina to form. Ideally the system should be around 60 ppm of total hardness.

## 4.0 Jointing Instructions

### 4.1 Sizes 6 to 54 mm

All installations must be completed in line with local regulations and by-laws governing the installation, and all applicable health and safety practices must be adhered to.

It is advisable to leave the fittings in the packaging prior to final installation to protect them from contamination and damage. As part of the installation process the space required, and the minimum distance between Conex Compression fittings, must be observed. For copper tubes in a R220 annealed condition and plastic pipes to BS 7291, EN 15875 and EN 15876 supporting liners must be used.

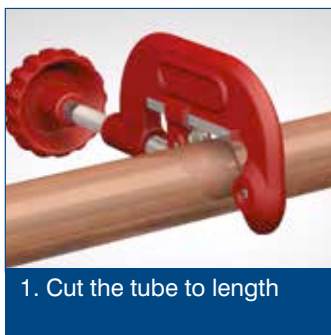

1. Cut the tube to length

- Tubes should be cut square to the required length using a rotary tube cutter or a pipe slice for plastic pipes.

**Note:** An angle grinder or cutting torch must not be used.



2. Clean

- Once the tube has been prepared, check for any deep scratches and scores in the tube.
- If either are visible cut the tube back and start the process again.



3. Deburr internally and externally

- The tubes should then be carefully deburred inside and out to remove all sharp edges and debris.



4. Assemble 1

- After the tube has been prepared and checked for scores and scratches, slide on the capnut and the compression ring.

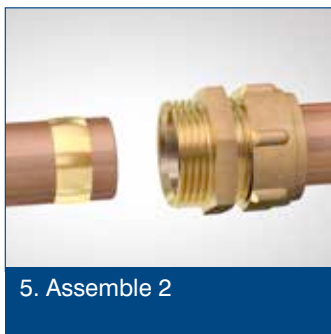

5. Assemble 2

- After the first capnut and compression ring has been located on to the tube add the main body of the fitting. This can be done by screwing the body in to the capnut.
- Slide the second capnut and compression ring on to the other side of the tube.



6. Hand tighten and mark

- Insert the tube up to the tube stop in to the main body of the fittings and hand tighten.
- This should be done on both of the capnuts so that the joint is secure and fixed in place.
- Mark each capnut and tube so that the number of turns can be counted.



7. Tighten the joint

- After both of the capnuts have been hand tightened use a flat face spanner, adjustable spanner (not serrated jaw type pliers) or torque wrench to tighten further.

**Note:** Use table 7 which states the number of turns required to complete the joint.

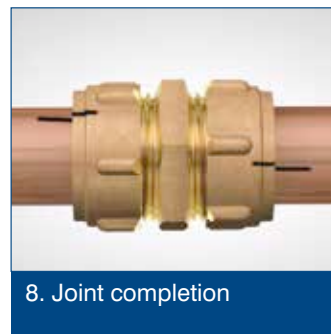

8. Joint completion

- Remember to count the number of turns using the guidance marks on the tube and fitting.
- The joint is now completed.

### 4.2 Minimum distances and insertion depths

Table 5:

Tube dimension	Minimum distance	Minimum tube length	Insertion depth
	A	L	E
mm			
6	14	46	16
8	15	49	17
10	15	51	18
12	16	56	20
15	16	58	21
16	17	61	22
18	17	65	24
20	17	65	24
22	17	67	25
28	17	69	26
35	19	81	31
42	21	85	34
54	24	106	41

### 4.3 Threaded joints for water applications

The use of a drinking water listed sealant or tape (e.g. PTFE) is recommended for making joints on fittings with taper male threads. For making joints with parallel connector threads, a good quality washer should be used to suit the particular application. Suitable drinking water approved washers are supplied with Conex Compression tap connector fittings and these should be used.

### 4.4 Connecting to plastic pipes

When joining soft copper tube to EN 1057-R220 or plastic pipes to BS 7291, EN 15875 and EN 15876, it is essential that an appropriate tube liner is also fitted. A Conex Compression joint makes a metal to metal seal which normally eliminates the need for jointing compounds and sealants. On larger sizes, particularly 54 mm, it may be necessary to use an additional WRAS approved sealant. Jointing instructions, when using sealant, are available from our technical department, [technical@ibpgroup.com](mailto:technical@ibpgroup.com).

Table 6: Spanner size for compression nut

Tube dimension	Spanner size
mm	
6	14
8	16
10	18
12	20
15	25
16	26
18	28
20	31
22	33
28	39
35	48
42	57
54	72
67	15
76	15
108	15

Figure 2

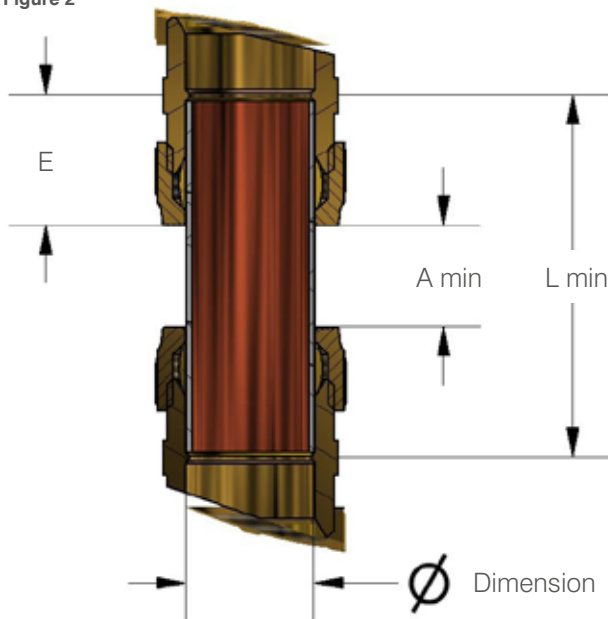

Table 7: See below table for the turns required to tighten the Conex Compression joint after hand tightening.

Material	Tube/Pipe specification	Size	6 mm to 18 mm	22 mm	28 mm to 54 mm	-
Copper	EN 1057 - R250 (Half hard)	No. of turns	1 1/4	1	3/4	-
	EN 1057 - R290 (Hard)	No. of turns	1	3/4	1/2	-
	EN 1057 - R220 (Annealed)	No. of turns Liner required SC1	1 1/4	1	-	-
Stainless steel	EN 10312 (BS4127)	Size	6 mm to 22 mm	28 mm	35 mm to 54 mm	-
		No. of turns	3/4	1/2	-	-
Carbon steel	EN 10305	Size	6 mm to 22 mm	28 mm	-	-
		No. of turns	3/4	1/2	-	-
Plastic pipe	Polybutylene (PB)	Size	10 mm	15 mm	22 mm	28 mm
		No. of turns	1 1/2	1 1/2	1 1/2	1 1/2
		Liner PP	C183031000PP	E203031000PP	G233031000PP	H293031000PP
	Cross linked polyethylene (PE-X)	Size	10 mm	15 mm	22 mm	28 mm
		No. of turns	1 1/2	1 1/2	1 1/2	1 1/2
		Liner PP	C183031000PP	E183031000PP	G233031000PP	H293031000PP

**Note:** For internal reducers the number of turns must be taken from the size of the connecting tubes not the size of the fitting.

Table 8:

Torque values	
Size (mm)	Torque value in Nm
6 to 10	20 +/- 5
15	30 +/- 5
22	40 +/- 5
28	55 +/- 5
35 to 54	70 +/- 5

The torque values given in Table 8 are given as an alternative method to the number of turns in Table 7 if torque wrenches are used. These figures are only for copper tube.

### 4.5 Flange fittings – sizes 67 to 108 mm

1. Ensure that the tube and fitting sizes are compatible. Then cut the tube end square, ensure tube retains its shape. The tube will then make even contact with the tube stop in the body of the fitting.
2. Remove any burrs from the tube, both inside and out.
3. One of two methods can be employed for making the joint.

a) The tube can be firmly inserted into the Conex Compression fitting without removing the compression plate and compression ring. Care should be taken to ensure that the compression ring is in the correct position and that the tube makes firm contact with the tube stop in the body of the fitting. The 3/8" BSW nuts are then tightened until hand tight and the same amount of thread shows on each bolt.

b) The compression plate and compression ring can be removed by first unscrewing the 3/8" BSW nuts. Then by locating the compression plate and compression ring onto the tube in logical sequence, the tube is then inserted into the fitting, or fitting onto the tube, until positive contact is reached. The compression ring and compression plate are then correctly situated in their original position, the nuts are replaced and tightened until hand tight, with the same amount of thread showing on each bolt.

4. In both cases the nuts are then further tightened a minimum of 2 full turns in increments of a 1/2 turn only, on each position in the sequence shown in Figure 3. To avoid over tightening the maximum number of turns is 2 1/2.

Tightening sequence

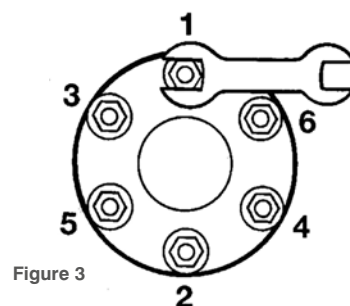
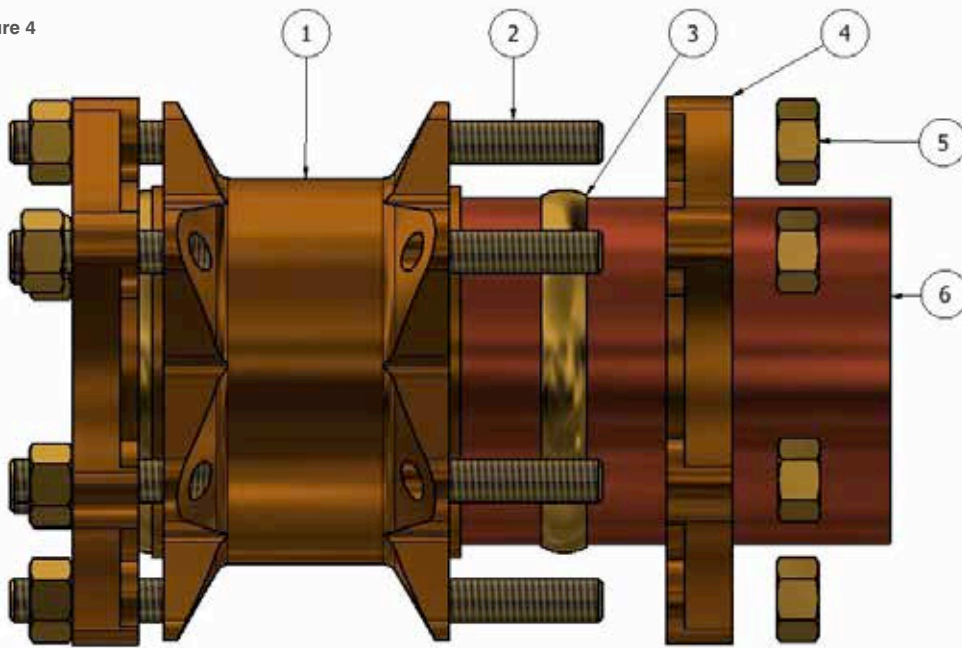

Figure 3

Figure 4



1. Fitting
2. Stud
3. Compression ring
4. Compression plate
5. Nut
6. Tube

**Note:** The compression plate before and after correct assembly should be parallel to the face of the fitting body.

#### 4.6 Internal reducers

Where dedicated fittings do not exist for reduction in tube-work, the reduction may be achieved with the use of internal reducers either as a three piece or one piece configuration. These are manufactured from DZR (dezincification resistant material CR) or gunmetal, thereby being resistant or immune to dezincification. They are suitable for use with our unique ribbed and octagonal capnut fittings (please refer to page 30 and 31 for more information).

Note: One piece reducers are not designed for use with plastic pipes. Only the three piece reducers - S68 can be used for plastic pipes. Internal reducers must not be used for gas applications and installations.

The minimum number of turns required is based on the reduced diameter end. Thus, for a 22 mm x 15 mm reducer, use the number of turns required for the 15 mm end. Refer to Table 7.

Reducers rely on a metal to metal seal and care should be taken to avoid damage prior to assembly. Should difficulty be experienced, the use of a WRAS listed sealant is permitted.

#### 4.7 Jointing instructions for gas applications

There are four quick steps to fitting a quality compression joint that is guaranteed to last:

- 1.** Make the joint in the same way you would join water tubes, following the standard catalogue instructions, but tighten the capnut 1/8 of a turn less than the specified number of turns after it has been tightened.
- 2.** Mark the position of the capnut in relation to the body of the fitting. Then dismantle the joint.
- 3.** Apply a thin smear of anaerobic sealant (in accordance with EN 751-1 approved for gas applications e.g. Loctite 542 or 577, Rood Foliac Super Red, etc) to the leading edge of the compression ring.
- 4.** Re-assemble the joint and re-tighten the capnut as before to its marked position. Finally, tighten the capnut again by another 1/8 of a turn.

## 5.0 Other Installations

### 5.1 Solar installations

12 mm to 28 mm Conex Compression fittings have been tested at ERA Technology Ltd. Surrey, for use in solar installations up to 200 °C with 50/50 glycol/water.

### 5.2 Gas installations

**Special instructions are required for the installation of gas.**

Conex Compression fittings are fully tested and approved for gas applications and pass the high temperature leakage rate test at 650 °C for 30 minutes. This criteria is fulfilled by the materials used and by the construction of the fitting.

Surface installations are possible, but the insertion behind plaster and below ground is not permitted.



## 6.0 Operating Parameters

### 6.1 Operating temperature and pressures with metal tubes

The maximum operating temperatures and pressures are shown below, based on EN 1254-2.

Table 9: Operating temperatures and maximum operating pressures - liquids

Operating temperature °C	Maximum operating pressure			
	Bar			
	6 to 15 mm	> 15 to 28 mm	> 28 to 54 mm	> 54 to 108 mm
30	25	16	16	10
65	25	13	10	6
95	16	10	7	5
110	16	8	6	4

Table 10: Operating temperatures and maximum operating pressures - gas up to 28 mm

Operating temperature °C	Maximum operating pressure
	Bar
-20 to 70	1

Table 11: Operating temperatures and maximum operating pressures - compressed air up to 28 mm

Operating temperature °C	Maximum operating pressure
	Bar
0 to 45	10









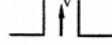
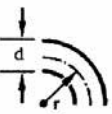
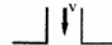
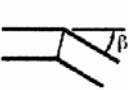

### 6.2 Operating temperatures and pressures with plastic pipe

For plastics, PE-X and PB pipes, please refer to the pipe manufacturer for operating parameters.

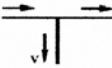
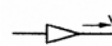
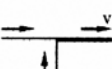
**Note:** For operating temperatures and pressures stated outside the above tables please contact the technical department on [technical@ibpgroup.com](mailto:technical@ibpgroup.com).

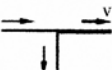
## 7.0 Loss coefficients

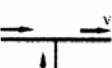
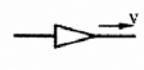
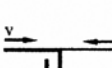
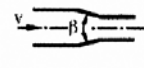
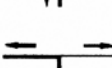
Table 12:

Symbol	Designation	$\zeta$	Application		Symbol	Designation	$\zeta$	Application	
			DW	H				DW	H
	Angle or elbow reference value in accordance with DIN 1988 T3	0,70	X	X		Distributor outlet	0,5	X	X
	Angle 90° r/d = 0,5 (r/d = 1,2 = 1,0 with fittings = 2,0 complying with DIN EN 1254) = 3,0	1,0 0,35 0,20 0,15	X X X X	X X X X		Collective inlet	1,0	X	X
	Angle $\beta = 90^\circ$ = 60° = 45°	1,3 0,8 0,4	X X X	X X X		Reservoir outlet	0,5	X	
	Crossover	0,5	X	X		Inlet	1,0	X	X
	Branch, square flow separation	1,3	X	X		Reducer	0,4	X	X
	Flow merging	0,9	X	X		Constriction $\beta$ - constant = 30° 45° 60°	0,02 0,04 0,07	X X X	X X X
	Clearance at flow merging	0,3	X	X		Expansion $\beta$ - constant = 10° 20° 30° 40°	0,10 0,15 0,20 0,20	X X X X	X X X X
	Clearance at flow merging	0,6	X	X		Expansion bends	1,0	X	X
	Counter-flow at flow merging	3,0	X	X		Compensator	2,0	X	X
	Counter-flow at flow separation	1,5	X	X		Compensator	2,0	X	X



## 8.0 The Range

Range code:

Brass
  DZR
  Red brass

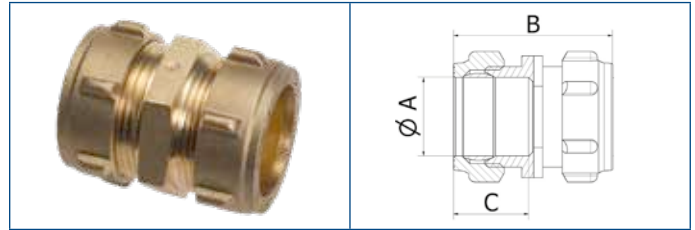

### Straight Coupler - 301

Code	Fitting size	A	B	C
DD-1020301--	12	12	45	20
TT-1020301--	14	14	45	21
EE-1020301--	15	15	44	21
UU-1020301--	16	16	47	22
FF-1020301--	18	18	50	24
VV-1020301--	20	20	51	24
GG-1020301--	22	22	52	25
HH-1020301--	28	28	53	26
JJ-1020301--	35	35	62	30
AA-5020301--	6	6	32	16
BB-5020301--	8	8	39	17
CC-5020301--	10	10	41	18
DD-5020301--	12	12	45	20
EE-5020301--	15	15	44	21
FF-5020301--	18	18	50	24
GG-5020301--	22	22	52	25
HH-5020301--	28	28	53	26
JJ-5020301--	35	35	62	30
KK-5020301--	42	42	70	34
NN-5020301--	54	54	83	40

16

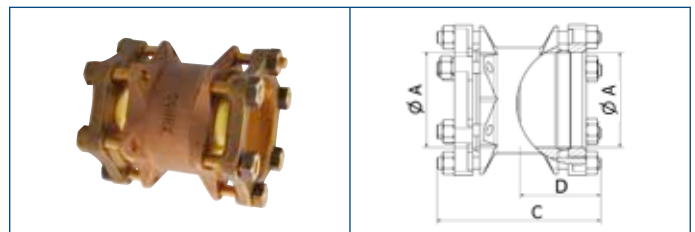

### Straight Coupler - 301

Code	Fitting size	A	B	C
QQ-2020301--	67	67	125	60
RR-2020301--	76	76	152	75
SS-2020301--	108	108	178	87

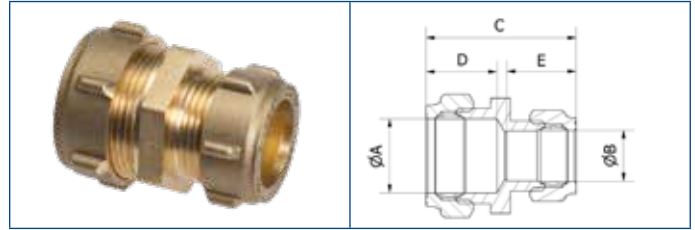

## Reduced Straight Coupler - 301

Code	Fitting size	A	B	C	D	E
ED-1020301--	15 x 12	15	12	43	21	20
FD-1020301--	18 x 12	18	12	46	24	20
GE-1020301--	22 x 15	22	15	48	25	21
GF-1020301--	22 x 18	22	18	51	25	24
HG-1020301--	28 x 22	28	22	52	26	25
BA-5020301--	8 x 6	8	6	31	18	16
CB-5020301--	10 x 8	10	8	37	18	17
DB-5020301--	12 x 8	12	8	39	20	17
DC-5020301--	12 x 10	12	10	40	20	18
EB-5020301--	15 x 8	15	8	40	21	17
EC-5020301--	15 x 10	15	10	41	21	18
ED-5020301--	15 x 12	15	12	43	21	20
FE-5020301--	18 x 15	18	15	47	24	21
GE-5020301--	22 x 15	22	15	51	25	24
HE-5020301--	28 x 15	28	15	51	26	24
HG-5020301--	28 x 22	28	22	53	26	25
JG-5020301--	35 x 22	35	22	58	30	26
JH-5020301--	35 x 28	35	22	58	30	26

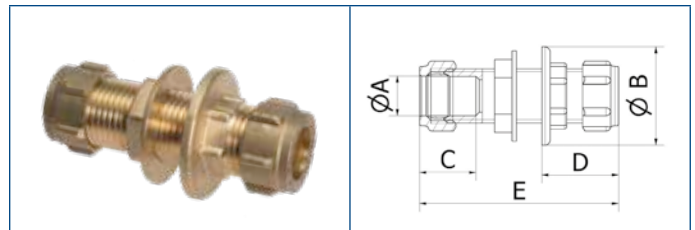

## Straight Coupler Bulkhead - 301BH

Code	Fitting size	A	B	C	D	E
EE-1020301BH	15	38	38	20	25	77
GG-1020301BH	22	22	45	24	30	82

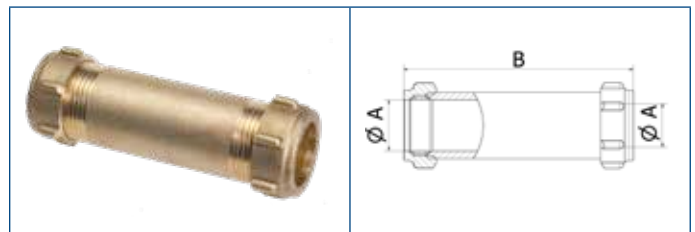

## Slip Coupler Burst Tube Repair - 301BP

Code	Fitting size	A	B
DZB1020301BP	12	12	100
EZB1020301BP	15	15	100
FZB1020301BP	18	18	100
GZB1020301BP	22	22	100

All sizes are in mm unless otherwise stated

Range code:

Brass
  DZR
  Red brass

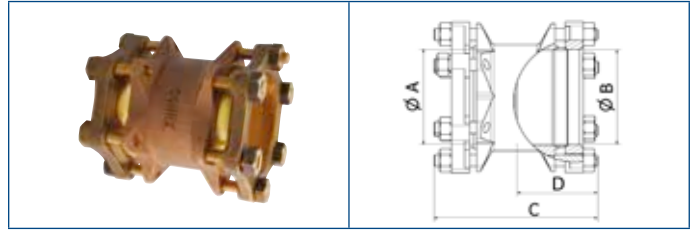

## Imperial to Metric Straight Coupler - 301IM

Code	Fitting size	A	B	C	D
R302020301IM	76 x 3"	76	3"	160	80

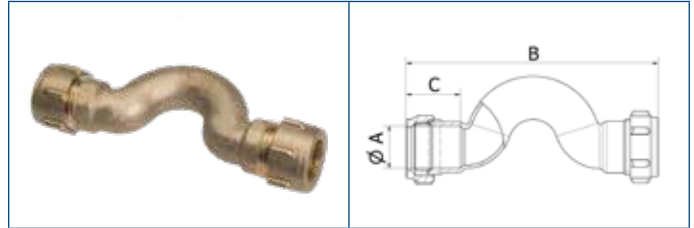

## Crossover - 301CO

Code	Fitting size	A	B	C
EE-5020301CO	15	15	107	22
GG-5020301CO	22	22	127	25

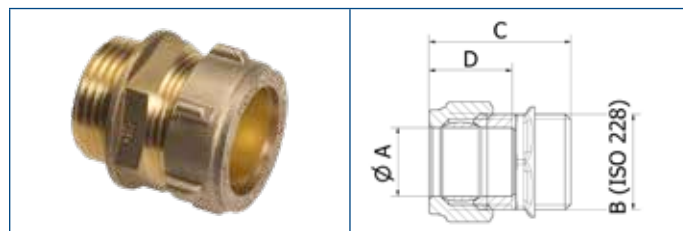

### Male Straight Coupler - 302

Code	Fitting size	A	B	C	D
A011020302--	6 x 1/4"	6	1/4"	27	8.5
D011020302--	12 x 1/4"	12	1/4"	34	16
D021020302--	12 x 3/8"	12	3/8"	35	20
D031020302--	12 x 1/2"	12	1/2"	35	20
E011020302--	15 x 1/4"	15	1/4"	34	21
E021020302--	15 x 3/8"	15	3/8"	35	21
E031020302--	15 x 1/2"	15	1/2"	37	21
E041020302--	15 x 3/4"	15	3/4"	38	21
F031020302--	18 x 1/2"	18	1/2"	36	24
F041020302--	18 x 3/4"	18	3/4"	43	24
G031020302--	22 x 1/2"	22	1/2"	37	25
G041020302--	22 x 3/4"	22	3/4"	42	25
G051020302--	22 x 1"	22	1"	41	25
H051020302--	28 x 1"	28	1"	45	26
H061020302--	28 x 1 1/4"	28	1 1/4"	48	26
J061020302--	35 x 1 1/4"	35	1 1/4"	52	30
K071020302--	42 x 1 1/2"	42	1 1/2"	57	34
N081020302--	54 x 2"	54	2"	70	40
A605020302--	6 x 1/8"	6	1/8"	27	16
B015020302--	8 x 1/4"	8	1/4"	30	17
B025020302--	8 x 3/8"	8	3/8"	32	17
B035020302--	8 x 1/2"	8	1/2"	32	17
C015020302--	10 x 1/4"	10	1/4"	31	18
C025020302--	10 x 3/8"	10	3/8"	33	18
C035020302--	10 x 1/2"	10	1/2"	33	18
D025020302--	12 x 3/8"	12	3/8"	35	20
D035020302--	12 x 1/2"	12	1/2"	35	20
E025020302--	15 x 3/8"	15	3/8"	35	21
E035020302--	15 x 1/2"	15	1/2"	37	21
E045020302--	15 x 3/4"	15	3/4"	38	21
F035020302--	18 x 1/2"	18	1/2"	36	24
F045020302--	18 x 3/4"	18	3/4"	43	24
G035020302--	22 x 1/2"	22	1/2"	37	25
G045020302--	22 x 3/4"	22	3/4"	42	25
G055020302--	22 x 1"	22	1"	41	25
H055020302--	28 x 1"	28	1"	45	26
H045020302--	28 x 3/4"	28	3/4"	41	26
J055020302--	35 x 1"	35	1"	48	30
J065020302--	35 x 1 1/4"	35	1 1/4"	52	30
K075020302--	42 x 1 1/2"	42	1 1/2"	57	34
N085020302--	54 x 2"	54	2"	70	40
Q092020302--	67 x 2 1/2"	67	2 1/2"	86	64
R302020302--	76 x 3"	76	3"	101	79
S402020302--	108 x 4"	108	4"	138	86

All sizes are in mm unless otherwise stated

Range code:

Brass
  DZR
  Red brass

## Male Straight Connector with Back Nut - 302B

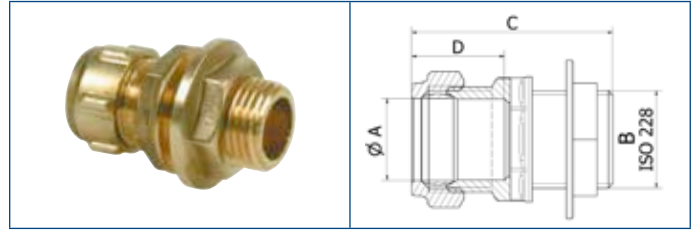

Code	Fitting size	A	B	C	D
E031020302B-	15 x 1/2"	15	1/2"	62	21
G041020302B-	22 x 3/4"	22	3/4"	72	25
H051020302B-	28 x 1"	28	1"	70	26
J061020302B-	35 x 1 1/4"	35	1 1/4"	62	30
K071020302B-	42 x 1 1/2"	42	1 1/2"	63	34
N081020302B-	54 x 2"	54	2"	69	40
Q092020302B-	67 x 2 1/2"	67	2 1/2"	146	60
R302020302B-	76 x 3"	76	3"	159	75

## Extended Male Straight Connector with Back Nut - 302CB

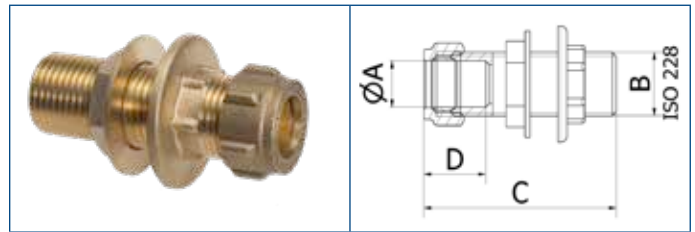

Code	Fitting size	A	B	C
E031020302CB	15 x 1/2 x 38	15	1/2	21
G041020302CB	22 x 3/4 x 38	22	3/4	25

20

## Male Straight Connector - 302TA

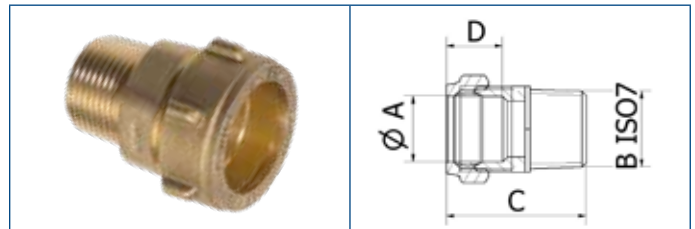

Code	Fitting size	A	B	C	D
C025020302TA	10 x 3/8"	10	3/8"	37	18
C035020302TA	10 x 1/2"	10	1/2"	41	18
D021020302TA	12 x 3/8"	12	3/8"	38	20
D031020302TA	12 x 1/2"	12	1/2"	42	20
T031020302TA	14 x 1/2"	14	1/2"	20	42
E021020302TA	15 x 3/8"	15	3/8"	35	21
E031020302TA	15 x 1/2"	15	1/2"	43	21
E041020302TA	15 x 3/4"	15	3/4"	46	21
U031020302TA	16 x 1/2"	16	1/2"	43	22
U041020302TA	16 x 3/4"	16	3/4"	45	22
F031020302TA	18 x 1/2"	18	1/2"	43	24
F041020302TA	18 x 3/4"	18	3/4"	45	24
G031020302TA	22 x 1/2"	22	1/2"	45	25
G041020302TA	22 x 3/4"	22	3/4"	48	25
G051020302TA	22 x 1"	22	1"	51	25
H041020302TA	28 x 3/4"	28	3/4"	50	26
H051020302TA	28 x 1"	28	1"	53	26

All sizes are in mm unless otherwise stated

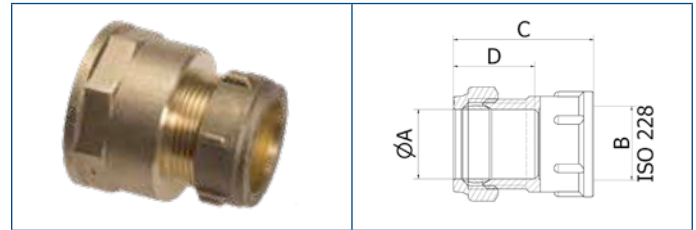

### Female Straight Connector - 303

Code	Fitting size	A	B	C	D
D021020303--	12 x 3/8"	12	3/8"	36	20
D031020303--	12 x 1/2"	12	1/2"	39.5	20
T031020303--	14 x 1/2"	14	1/2"	40	20
E021020303--	15 x 3/8"	15	3/8"	36.5	21
E031020303--	15 x 1/2"	15	1/2"	39.5	21
E041020303--	15 x 3/4"	15	3/4"	42.5	21
E051020303--	15 x 1"	15	1"	43.5	21
U031020303--	16 x 1/2"	16	1/2"	42	22
F031020303--	18 x 1/2"	18	1/2"	41.5	24
F041020303--	18 x 3/4"	18	3/4"	42.5	24
G031020303--	22 x 1/2"	22	1/2"	43	25
G041020303--	22 x 3/4"	22	3/4"	43	25
G051020303--	22 x 1"	22	1"	48	25
H041020303--	28 x 3/4"	28	3/4"	43	26
H051020303--	28 x 1"	28	1"	48	26
H061020303--	28 x 1 1/4"	28	1 1/4"	51	26
B015020303--	8 x 1/4"	8	1/4"	32.5	17
B025020303--	8 x 3/8"	8	3/8"	33.5	17
B035020303--	8 x 1/2"	8	1/2"	36.5	17
C015020303--	10 x 1/4"	10	1/4"	34	18
C025020303--	10 x 3/8"	10	3/8"	34	18
C035020303--	10 x 1/2"	10	1/2"	37	18
D025020303--	12 x 3/8"	12	3/8"	36	20
D035020303--	12 x 1/2"	12	1/2"	39.5	20
E025020303--	15 x 3/8"	15	3/8"	36.5	21
E035020303--	15 x 1/2"	15	1/2"	39.5	21
E045020303--	15 x 3/4"	15	3/4"	42.5	21
F035020303--	18 x 1/2"	18	1/2"	41.5	24
F045020303--	18 x 3/4"	18	3/4"	42.5	24
G035020303--	22 x 1/2"	22	1/2"	40	25
G045020303--	22 x 3/4"	22	3/4"	43.5	25
G055020303--	22 x 1"	22	1"	49	25
H045020303--	28 x 3/4"	28	3/4"	43	26
H055020303--	28 x 1"	28	1"	48	26
J055020303--	35 x 1"	35	1"	56	30
J065020303--	35 x 1 1/4"	35	1 1/4"	57	30
K075020303--	42 x 1 1/2"	42	1 1/2"	63	34
N085020303--	54 x 2"	54	2"	72	40
Q092020303--	67 x 2 1/2"	67	2 1/2"	93	64
R302020303--	76 x 3"	76	3"	112	79

Range code:

Brass
  DZR
  Red brass

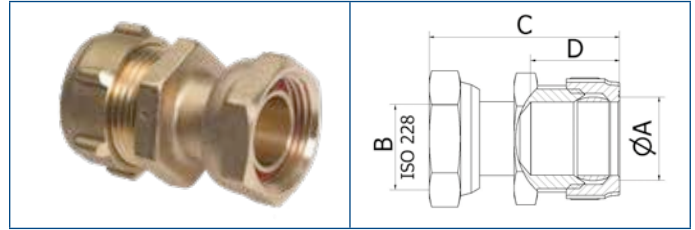

## Straight Tap Connector Max 60 °C - 303SF

Code	Fitting size	A	B	C	D
E031020303SF	15 x 1/2"	15	1/2"	35	21
G041020303SF	22 x 3/4"	22	3/4"	39	25
E035020303SF	15 x 1/2"	15	1/2"	35	21
E045020303SF	15 x 3/4"	15	3/4"	36	21
G045020303SF	22 x 3/4"	22	3/4"	39	25

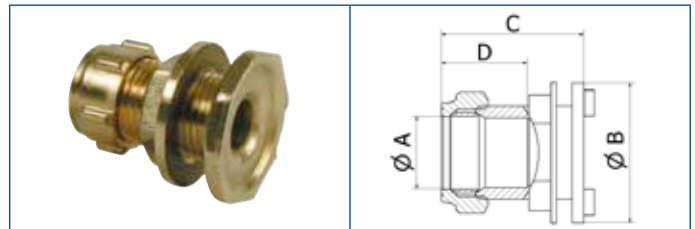

## Tank Connector - 321

Code	Fitting size	A	B	C	D
E--1020321--	15	15	35	49	21
G--1020321--	22	22	43	46	25
H--1020321--	28	28	49	48	26
J--1020321--	35	35	57	46	30
N--5020321--	54	54	82	73	40
H--5020321--	28	28	49	48	25
K--5020321--	42	42	63	49	34



## Female Straight Connector for Pillar Taps - 303ST (short thread)

Code	Fitting size	A	B	C	D
E031020303ST	15	15	1/2"	33	21
E041020303ST	15	15	3/4"	33	21
G041020303ST	22	22	3/4"	33	25

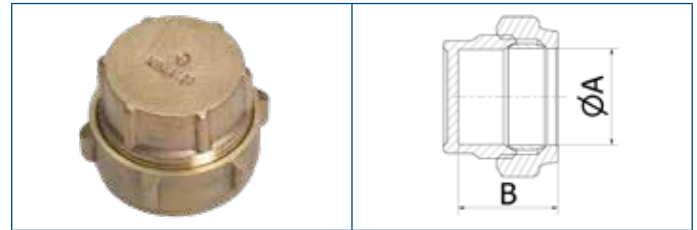
**Stop End - 323**

Code	Fitting size	A	B
B--1020323--	8	8	19
D--1020323--	12	12	22
E--1020323--	15	15	26
G--1020323--	22	22	27
H--1020323--	28	28	31
B--5020323--	8	8	22
C--5020323--	10	10	22
D--5020323--	12	12	25
E--5020323--	15	15	26
F--5020323--	18	18	29
G--5020323--	22	22	27
H--5020323--	28	28	40
J--5020323--	35	35	35
K--5020323--	42	42	37
N--5020323--	54	54	50

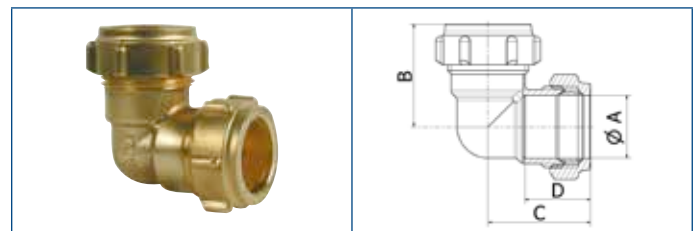
**Elbow - 401**

Code	Fitting size	A	B	C	D
DD-1020401--	12	12	29	29	20
TT-1020401--	14	14	31	31	21
EE-1020401--	15	15	31	31	21
UU-1020401--	16	16	32	32	22
FF-1020401--	18	18	35	35	24
GG-1020401--	22	22	37	37	25
HH-1020401--	28	28	42	42	26
JJ-1020401--	35	35	48	48	30
KK-1020401--	42	42	56	56	34
NN-1020401--	54	54	69	69	40
AA-5020401--	6	6	23	23	23
BB-5020401--	8	8	24	25	17
CC-5020401--	10	10	28	28	18
DD-5020401--	12	12	29	30	20
EE-5020401--	15	15	31	32	21
FF-5020401--	18	18	35	35	29
GG-5020401--	22	22	37	40	25
HH-5020401--	28	28	42	42	26
JJ-5020401--	35	35	48	48	30
KK-5020401--	42	42	56	56	34
NN-2020401--	54	54	69	69	40
QQ-2020401--	67	67	102	102	64
RR-2020401--	76	76	114	114	79

All sizes are in mm unless otherwise stated

Range code:

Brass
  DZR
  Red brass

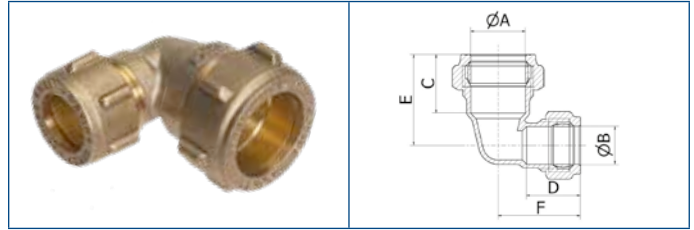

## Reduced Elbow - 401

Code	Fitting size	A	B	C	D	E	F
ED-1020401--	15 x 12	15	12	21	20	28	26
FE-1020401--	18 x 15	18	15	24	21	34	33
GE-1020401--	22 x 15	22	15	25	21	34	25
DC-5020401--	12 x 10	12	10	20	18	28	22
EC-5020401--	15 x 10	15	10	21	19	31	30
GE-5020401--	22 x 15	22	15	25	21	34	31
HE-5020401--	28 x 15	28	15	26	21	38	34
HG-5020401--	28 x 22	28	22	26	25	38	39

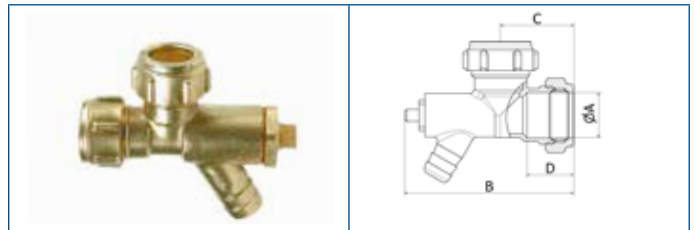

## Elbow with Drain Tap - 401DA

Code	Fitting size	A	B	C	D
EE-1020401DA	15	15	81	31	22
GG-1020401DA	22	22	91	37	25
HH-1020401DA	28	28	97	42	26

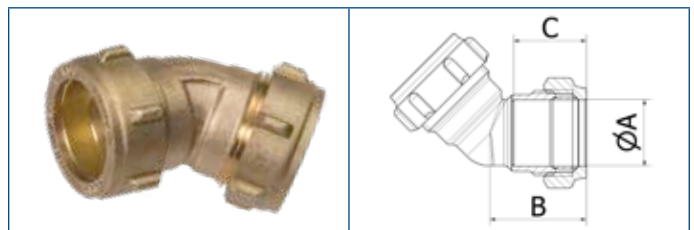

## Obtuse Elbow - 401/O

Code	Fitting size	A	B	C
EE-1020401/O	15	15	24	21
GG-1020401/O	22	22	28	25
HH-1020401/O	28	28	30	26



### Slow Bend - 401S

Code	Fitting size	A	B	C	D
EE-5020401S-	15	15	41	19	22
GG-5020401S-	22	22	46	22	24
HH-5020401S-	28	28	53	27	26

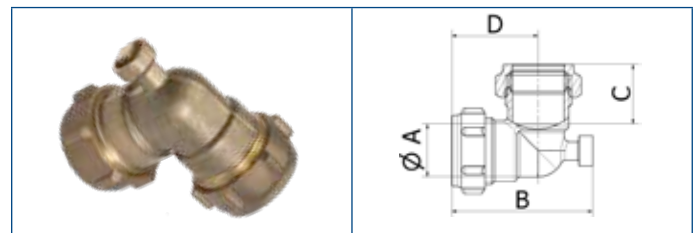

### Elbow with Air Vent - 401V

Code	Fitting size	A	B	C	D
EE-1020401V-	15	15	22	22	31
GG-1020401V-	22	22	60	25	37

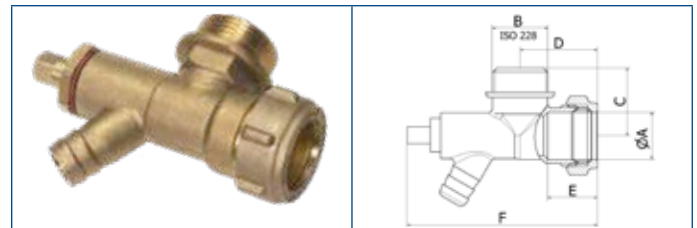

### Male Elbow with Drain Tap - 402DA

Code	Fitting size	A	B	C	D	E	F
G041020402DA	22 x 3/4"	22	3/4"	33	38	25	91

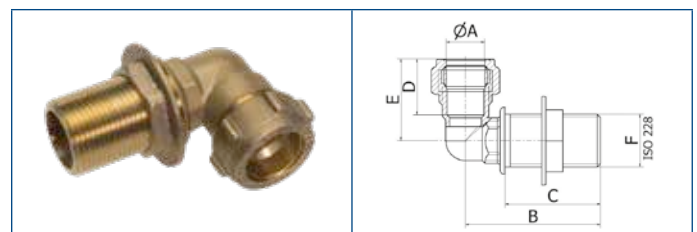

### Extended Male Elbow with Back Nut - 402CB

Code	Fitting size	A	B	C	D	E	F
E031020402CB	15 x 1/2" x 38	15	54	38	21	34	1/2"
G041020402CB	22 x 1/2" x 38	22	59	38	25	38	1/2"

Range code:

Brass
  DZR
  Red brass

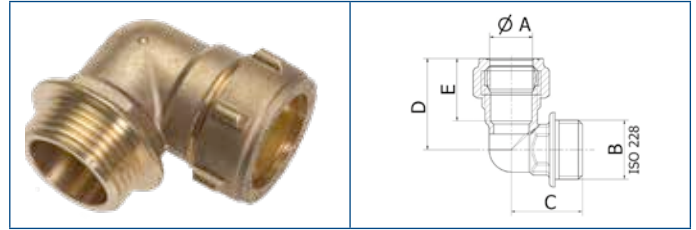

## Male Elbow - 402

Code	Fitting size	A	B	C	D	E
E031020402--	15 x 1/2"	15	1/2"	24	33	21
E041020402--	15 x 3/4"	15	3/4"	29	35	21
F031020402--	18 x 1/2"	18	1/2"	27	37	24
G041020402--	22 x 3/4"	22	3/4"	31	43	25
G051020402--	22 x 1"	22	1"	38	43	25
H041020402--	28 x 3/4"	28	3/4"	37	39	26
B015020402--	8 x 1/4"	8	1/4"	20	27	17
C025020402--	10 x 3/8"	10	3/8"	23	30	18
C035020402--	10 x 1/2"	10	1/2"	24	32	18
D025020402--	12 x 3/8"	12	3/8"	23	30	20
D035020402--	12 x 1/2"	12	1/2"	24	34	20
E025020402--	15 x 3/8"	15	3/8"	23	30	21
E035020402--	15 x 1/2"	15	1/2"	24	33	21
E045020402--	15 x 3/4"	15	3/4"	29	35	21
F035020402--	18 x 1/2"	18	1/2"	27	37	24
F045020402--	18 x 3/4"	18	3/4"	29	37	24
G035020402--	22 x 1/2"	22	1/2"	30	40	25
G045020402--	22 x 3/4"	22	3/4"	31	38	25
H055020402--	28 x 1"	28	1"	38	43	26
J065020402--	35 x 1 1/4"	35	1 1/4"	45	49	30
K075020402--	42 x 1 1/2"	42	1 1/2"	47	56	34
N082020402--	54 x 2"	54	2"	48	69	40
Q092020402--	67 x 2.1/2"	67	2 1/2"	83	109	60

26



## Male Elbow Taper - 402TA

Code	Fitting size	A	B	C	D	E
D021020402TA	12 x 3/8"	12	3/8"	31	20	27
D031020402TA	12 x 1/2"	12	1/2"	33	20	31
T031020402TA	14 x 1/2"	14	1/2"	35	21	31
E021020402TA	15 x 3/8"	15	3/8"	29	21	30
E031020402TA	15 x 1/2"	15	1/2"	31	21	33
E041020402TA	15 x 3/4"	15	3/4"	34	21	35
U031020402TA	16 x 1/2"	16	1/2"	34	22	35
U041020402TA	16 x 3/4"	16	3/4"	37	22	38
F031020402TA	18 x 1/2"	18	1/2"	35	24	36
F041020402TA	18 x 3/4"	18	3/4"	36	24	34
G041020402TA	22 x 3/4"	22	3/4"	37	25	38
G051020402TA	22 x 1"	22	1"	42	25	40
H051020402TA	28 x 1"	28	1"	45	26	43
C035020402TA	10 x 1/2"	10	1/2"	31	18	32

All sizes are in mm unless otherwise stated

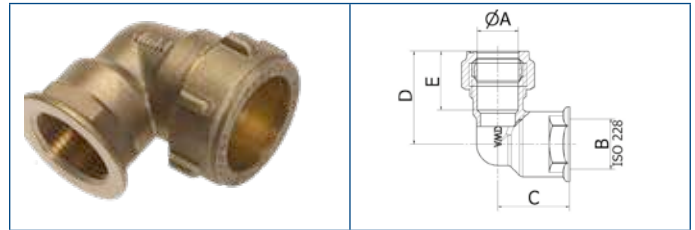

## Female Elbow - 403

Code	Fitting size	A	B	C	D	E
D031020403--	12 x 1/2"	12	1/2"	22.5	33	20
E031020403--	15 x 1/2"	15	1/2"	23	34	21
E041020403--	15 x 3/4"	15	3/4"	25	35	21
F031020403--	18 x 1/2"	18	1/2"	26	36	24
F041020403--	18 x 3/4"	18	3/4"	30	40	24
G031020403--	22 x 1/2"	22	1/2"	25	37	25
G041020403--	22 x 3/4"	22	3/4"	29	39	25
G051020403--	22 x 1"	22	1"	31	43	25
H041020403--	28 x 3/4"	28	3/4"	33	40	26
H051020403--	28 x 1"	28	1"	36	42	26
K071020403--	42 x 1 1/2"	42	1 1/2"	48.5	55	34
B015020403--	8 x 1/4"	8	1/4"	17	27	17
C025020403--	10 x 3/8"	10	3/8"	19	29	18
C035020403--	10 x 1/2"	10	1/2"	23	33	18
D025020403--	12 x 3/8"	12	3/8"	19	30.5	20
D035020403--	12 x 1/2"	12	1/2"	22.5	33	20
E025020403--	15 x 3/8"	15	3/8"	21.5	32	20
E035020403--	15 x 1/2"	15	1/2"	23	34	21
E045020403--	15 x 3/4"	15	3/4"	25	35	21
F045020403--	18 x 3/4"	18	3/4"	30	40	24
G035020403--	22 x 1/2"	22	1/2"	25	37	24
G045020403--	22 x 3/4"	22	3/4"	29	40	25
H055020403--	28 x 1"	28	1"	36	42	26
J065020403--	35 x 1 1/4"	35	1 1/4"	35	44	30
K072020403--	42 x 1 1/2"	42	1 1/2"	48	55	34
N082020403--	54 x 2"	54	2"	55	70	40

27

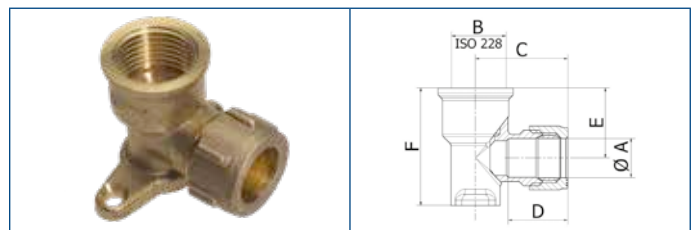

## Female Wall Plate Elbow 2 Hole - 403W

Code	Fitting size	A	B	C	D	E	F
D031020403W-	12 x 1/2"	12	1/2"	33	18	25	38
T031020403W-	14 x 1/2"	14	1/2"	44	21	24	42
E031020403W-	15 x 1/2"	15	1/2"	44	21	24	42
E035020403W-	15 x 1/2"	15	1/2"	44	21	24	42

All sizes are in mm unless otherwise stated

Range code:

Brass
  DZR
  Red brass

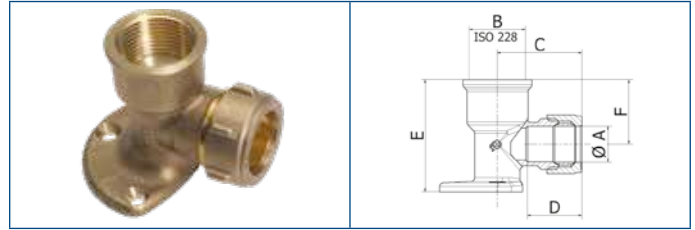

## Female Wall Plate Elbow 3 Hole - 403WL

Code	Fitting size	A	B	C	D	E	F
E031020403WL	15 x 1/2"	15	1/2"	34	21	45	25
U031020403WL	16 x 1/2"	16	1/2"	34	21	45	25
F031020403WL	18 x 1/2"	18	1/2"	37	24	43	30
G031020403WL	22 x 1/2"	22	1/2"	38	25	47	35
H051020403WL	28 x 1"	28	1/2"	44	26	65	40
C035020403WL	10 x 1/2"	10	1/2"	34	18	38	23
D035020403WL	12 x 1/2"	12	1/2"	33	20	38	23
E035020403WL	15 x 1/2"	15	1/2"	34	21	45	25
G045020403WL	22 x 3/4"	22	3/4"	38	24	54	32

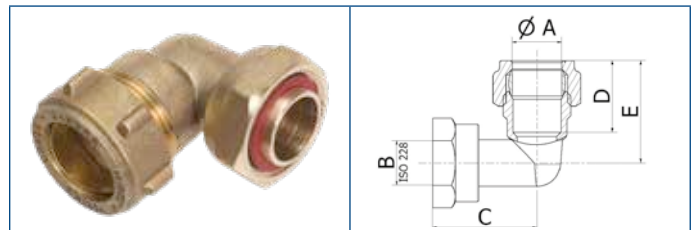

## Bent Tap Connector - 403SF

Code	Fitting size	A	B	C	D	E
E031020403SF	15 x 1/2"	15	1/2"	25	21	31
G031020403SF	22 x 1/2"	22	1/2"	29	25	33
G041020403SF	22 x 3/4"	22	3/4"	30	25	36
E035020403SF	15 x 1/2"	15	1/2"	25	21	31

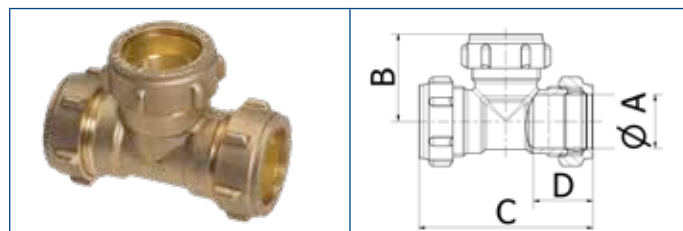

### Equal Tee - 601EQ

Code	Fitting size	A	B	C	D
DDD1020601EQ	12	12	29	58	20
TTT1020601EQ	14	14	31	63	21
EEE1020601EQ	15	15	31	63	21
FFF1020601EQ	18	18	33	66	24
GGG1020601EQ	22	22	36	73	25
HHH1020601EQ	28	28	42	83	26
AAA5020601EQ	6	6	22	45	15
BBB5020601EQ	8	8	25	50	17
CCC5020601EQ	10	10	28	56	18
DDD5020601EQ	12	12	29	58	20
EEE5020601EQ	15	15	31	63	21
UUU5020601EQ	16	18	32	63	22
FFF5020601EQ	18	18	33	66	24
GGG5020601EQ	22	22	36	73	26
HHH5020601EQ	28	28	42	83	26
JJJ5020601EQ	35	35	53	106	30
KKK5020601EQ	42	42	62	123	34
NNN2020601EQ	54	54	63	124	40
QQQ2020601EQ	67	67	98	196	64
RRR2020601EQ	76	76	118	240	79

Range code:

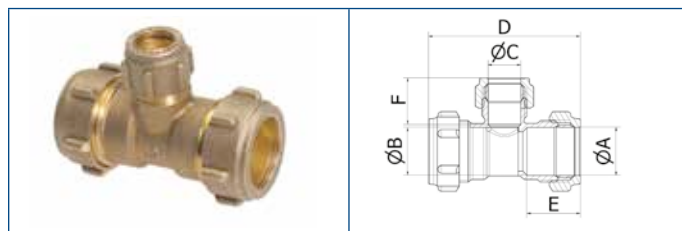
 Brass
  DZR
  Red brass

## Tee Reduced Branch - 601RB

Code	Fitting size	A	B	C	D	E	F
GGE1020601--	22 x 22 x 15	22	22	15	69	25	21
HHE1020601--	28 x 28 x 15	28	28	15	68	26	21
HHG1020601--	28 x 28 x 22	28	28	22	76	26	25
NNE1020601--	54 x 54 x 15	54	54	15	114	40	21
NNG1020601--	54 x 54 x 22	54	54	22	114	40	25
NNH1020601--	54 x 54 x 28	54	54	28	114	40	26
NNJ2020601--	54 x 54 x 35	54	54	35	114	40	30
NNK2020601--	54 x 54 x 42	54	54	42	118	40	34
EEC5020601--	15 x 15 x 10	15	15	10	63	21	18
EED5020601--	15 x 15 x 12	15	15	12	64	21	20
FFD5020601--	18 x 18 x 12	18	18	12	61	24	20
FFE5020601--	18 x 18 x 15	18	18	15	68	24	21
GGD5020601--	22 x 22 x 12	22	22	12	70	25	20
GGE5020601--	22 x 22 x 15	22	22	15	69	25	21
GGF5020601--	22 x 22 x 18	22	22	18	73	25	24
HHE5020601--	28 x 28 x 15	28	28	15	68	26	24
HHG5020601--	28 x 28 x 22	28	28	22	76	26	25
JJE5020601--	35 x 35 x 15	35	35	15	82	30	24
JJG5020601--	35 x 35 x 22	35	35	22	82	30	25
JJH5020601--	35 x 35 x 28	35	35	28	89	30	26
KKE5020601--	42 x 42 x 15	42	42	15	92	34	24
KKG5020601--	42 x 42 x 22	42	42	22	92	34	25
KKH5020601--	42 x 42 x 28	42	42	28	106	34	26
KKJ5020601--	42 x 42 x 35	42	42	35	106	34	30
NNK5020601--	54 x 54 x 42	42	42	54	37	40	34
QQH2020601--	67 x 67 x 28	67	67	28	151	64	25
QQK2020601--	67 x 67 x 42	67	67	42	167	64	34
QQN2020601--	67 x 67 x 54	67	67	54	177	64	40
RRH2020601--	76 x 76 x 28	76	76	28	183	79	25
RRN2020601--	76 x 76 x 54	76	76	54	209	79	40



### Three-way Equal Tee - 601C

Code	Fitting size	A	B
EEE5020601C-	15 x 15 x 15	15	34
GGG5020601C-	22 x 22 x 22	22	37

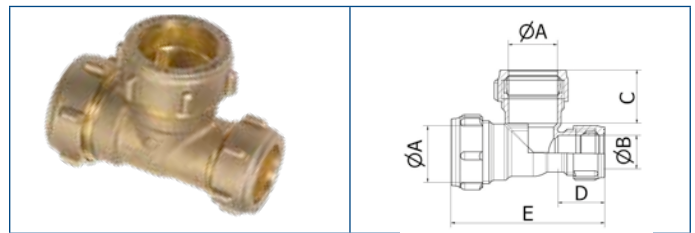

### Tee Reduced End - 601RE

Code	Fitting size	A	B	C	D	E
FEF1020601--	18 x 15 x 18	18	15	24	21	26
GEG1020601--	22 x 15 x 22	22	15	24	21	70
HEH1020601--	28 x 15 x 28	28	15	26	21	81
DDE5020601--	12 x 12 x 15	12	15	20	64	20
FEF5020601--	18 x 15 x 18	18	15	24	21	68
GEG5020601--	22 x 15 x 22	22	15	24	21	70
HGH5020601--	28 x 22 x 28	22	15	26	21	81

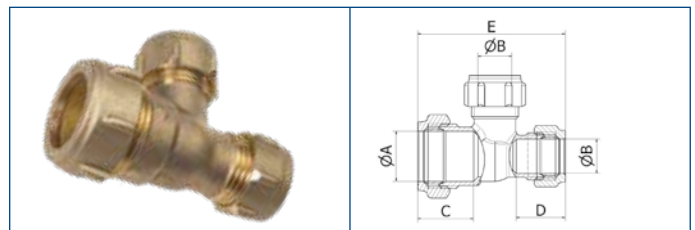

### Tee Reduced End and Branch - 601REB

Code	Fitting size	A	B	C	D	E
GEE1020601--	22 x 15 x 15	22	15	25	21	65
EDD5020601--	15 x 12 x 12	15	12	21	18	64
GEE5020601--	22 x 15 x 15	22	15	25	21	65
HGG5020601--	28 x 22 x 22	28	22	26	25	75

Range code:

Brass
  DZR
  Red brass

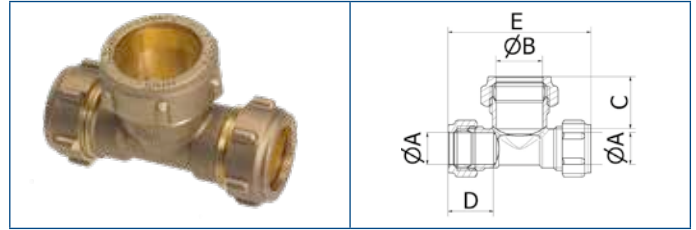

### Tee Reduced Both Ends - 601REE

Code	Fitting size	A	B	C	D	E
EEG5020601-	15 x 15 x 22	15	22	25	21	70
GGH5020601--	22 x 22 x 28	22	28	26	25	82

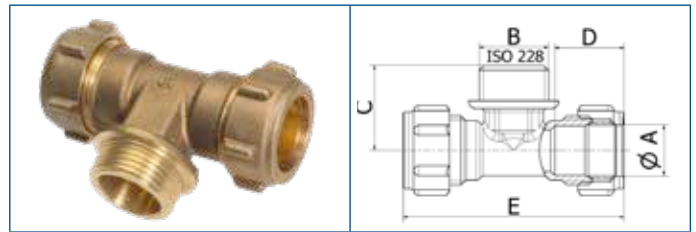

### Tee with Male Branch - 615

Code	Fitting size	A	B	C	D	E
EE35020615--	15 x 1/2" x 15	15	1/2"	26	21	68
GG35020615--	22 x 1/2" x 22	22	1/2"	31	25	73
GG45020615--	22 x 3/4" x 22	22	3/4"	33	25	77

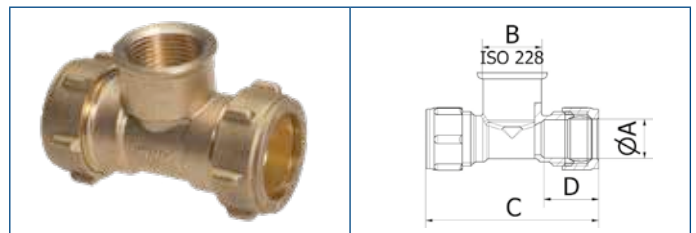

### Tee with Female Branch - 617

Code	Fitting size	A	B	C	D
TT31020617--	14 x 14 x 1/2"	14	1/2"	62	21
EE11020617--	15 x 15 x 1/4"	15	1/4"	63	21
EE31020617--	15 x 15 x 1/2"	15	1/2"	66	21
EE41020617--	15 x 15 x 3/4"	15	3/4"	74	21
UU41020617--	16 x 16 x 3/4"	16	3/4"	74.5	21.5
FF31020617--	18 x 18 x 1/2"	18	1/2"	72	24
FF41020617--	18 x 18 x 3/4"	18	3/4"	80	24
GG31020617--	22 x 22 x 1/2"	22	1/2"	73	25
GG51020617--	22 x 22 x 1"	22	1"	88	25
HH41020617--	28 x 28 x 3/4"	28	3/4"	80	26
DD25020617--	12 x 12 x 3/8"	12	3/8"	61	20.5
DD35020617--	12 x 12 x 1/2"	12	1/2"	67	24
EE35020617--	15 x 15 x 1/2"	15	1/2"	66	21
GG35020617--	22 x 22 x 1/2"	22	1/2"	73	25
GG45020617--	22 x 22 x 3/4"	22	3/4"	78	25
HH35020617--	28 x 28 x 1/2"	28	1/2"	77	26
HH55020617--	28 x 28 x 1"	28	1"	86	26

All sizes are in mm unless otherwise stated

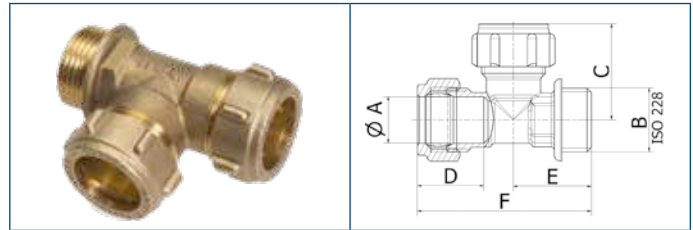

### Tee with Male End - 631

Code	Fitting size	A	B	C	D	E	F
E3E5020631--	15 x 1/2" x 15	15	1/2"	34	21	26	48
G4G5020631--	22 x 3/4" x 22	22	3/4"	37	25	33	70

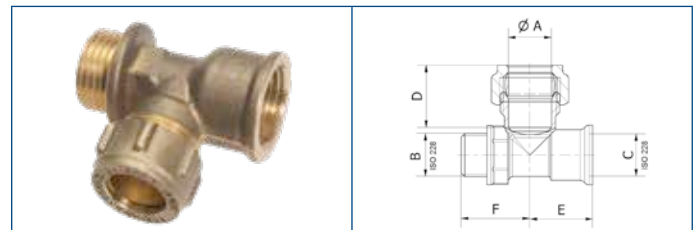

### Tee with Male and Female Ends - 645

Code	Fitting size	A	B	C	D	E	F
33E1020645--	1/2 x 1/2 x 15	15	1/2"	1/2"	21	23	25

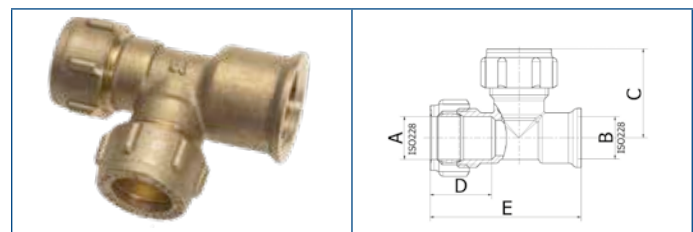

### Tee with Female End - 684

Code	Fitting size	A	B	C	D	E
G3G1020684--	22 x 1/2" x 22	22	1/2"	37	36	60.5
G4G1020684--	22 x 3/4" x 22	22	3/4"	40	40	66
H5H1020684--	28 x 1" x 28	28	1"	45	26	79
E3E5020684--	15 x 1/2" x 15	15	1/2"	33	22	55
G3G5020684--	22 x 1/2" x 22	22	1/2"	37	36	60.5



### Cross - Equal - 901

Code	Fitting size	A	B	C	D
EEEE1020901-	15 x 15 x 15 x 15	15	63	32	21
GGGG1020901	22 x 22 x 22 x 22	22	74	37	25

Range code:

Brass
  DZR
  Red brass



## Capnut - 63

Code	Fitting size	A	B
A--1020063--	6	13	15
B--1020063--	8	16	18
C--1020063--	10	18	21
D--1020063--	12	20	22
T--1020063--	14	23	26
E--1020063--	15	24	27
U--1020063--	16	25	28
F--1020063--	18	27	31
G--1020063--	22	32	37
H--1020063--	28	39	45
J--1020063--	35	47	50
K--1020063--	42	55	59
N--1020063--	54	70	76



## Blank Capnut - 63B

Code	Fitting size	A	B
B--1020063B-	8	16	18
C--1020063B-	10	18	21
D--1020063B-	12	20	22
E--1020063B-	15	24	27
F--1020063B-	18	18	8
G--1020063B-	22	32	37
H--1020063B-	28	39	45
J--1020063B-	35	47	50
K--1020063B-	42	55	59
N--1020063B-	54	70	76



## Compression Ring (Imperial) - 65

Code	Fitting size	A	B
04-1020065--	3/4"	3/4" (24)	8.5
05-1020065--	1"	1" (31)	8.5
06-1020065--	1 1/4"	1 1/4" (38)	9.5
30-1020065--	3"	3" (80)	15

All sizes are in mm unless otherwise stated



**Compression Ring - 65**

Code	Fitting size	A	B
A--1020065--	6	6	6.2
B--1020065--	8	8	6.2
C--1020065--	10	10	7.2
D--1020065--	12	12	8
T--1020065--	14	14	8
E--1020065--	15	15	8
U--1020065--	16	16	8
F--1020065--	18	18	8
V--1020065--	20	20	8
G--1020065--	22	22	9
H--1020065--	28	28	9
J--1020065--	35	35	10
K--1020065--	42	42	10
N--1020065--	54	54	13
Q--1020065--	67	67	14
R--1020065--	76	76	15
S--1020065--	108	108	17

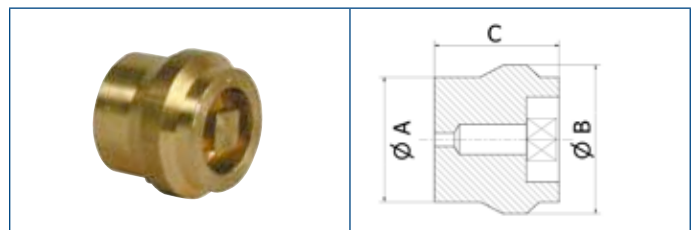

**Air Vent - 63V**

Code	Fitting size	A	B	C
E--1020063V	15	15	18	13

Range code:

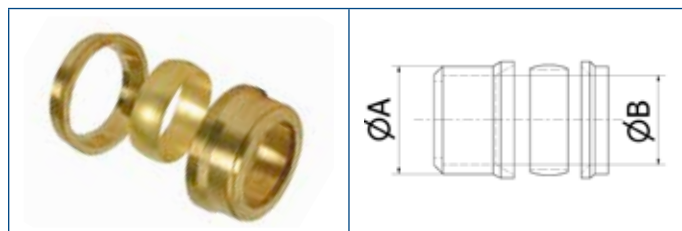
 Brass
  DZR
  Red brass

## Internal Reducer - S68

Code	Fitting size	A	B
KJ-1022068--	42 x 35	42	35
NJ-1022068--	54 x 35	54	35
NK-1022068--	54 x 42	54	42
CB-5020068--	10 x 8	10	8
DB-5020068--	12 x 8	12	8
DC-5020068--	12 x 10	12	10
EB-5020068--	15 x 8	15	8
EC-5020068--	15 x 10	15	10
ED-5020068--	15 x 12	15	12
ET-5020068--	15 x 14	15	14
FD-5020068--	18 x 12	18	12
FE-5020068--	18 x 15	18	15
FY-5020068--	18 x 16	18	16
GD-5020068--	22 x 12	22	22
GE-5020068--	22 x 15	22	15
GF-5020068--	22 x 18	22	18
HE-5020068--	28 x 15	28	15
HF-5020068--	28 x 18	28	18
HG-5020068--	28 x 22	28	22
JE-5020068--	35 x 15	35	15
JG-5020068--	35 x 22	35	22
JH-5020068--	35 x 28	35	28
KE-5020068--	42 x 15	42	15
KG-5020068--	42 x 22	42	22
KH-5020068--	42 x 28	42	28
KJ-5020068--	42 x 35	42	35
NE-5020068--	54 x 15	54	15
NG-5020068--	54 x 22	54	22
NH-5020068--	54 x 28	54	28
NJ-5020068--	54 x 35	54	35
NK-5020068--	54 x 42	54	42
KJ-1222068--	42 x 35	42	35
NJ-1222068--	54 x 35	54	35
NK-1222068--	54 x 42	54	42
QN-2020068--	67 x 54	67	54
RQ-2020068--	76 x 67	76	67
RN-2020068E-	76 x 54	76	54

All sizes are in mm unless otherwise stated



### Internal Reducer - 68S (for copper tube only)

Code	Fitting size	A	B	C	D
BA-5020068S-	8 x 6	13	6	11	8



### Male to Female Adaptor - S68SP

(for copper tube only)

Code	Fitting size	A	B	C	D
CB-5020M68SP	10 x 8	10	8	14	13
DB-5020M68SP	12 x 8	12	8	15	14
DC-5020M68SP	12 x 10	12	10	15	14
EB-5020M68SP	15 x 8	15	8	14.5	13.5
EC-5020M68SP	15 x 10	15	10	14.5	13.5
ED-5020M68SP	15 x 12	15	12	17.5	16.5
FD-5020M68SP	18 x 12	18	12	18	17
FE-5020M68SP	18 x 15	18	15	18	17
GD-5020M68SP	22 x 12	22	12	17.5	16.5
GE-5020M68SP	22 x 15	22	15	17.5	16.5
GF-5020M68SP	22 x 18	22	18	17.5	16.5
HE-5020M68SP	28 x 15	28	15	21	20
HF-5020M68SP	28 x 18	28	18	21	20
HG-5020M68SP	28 x 22	28	22	21	20
JG-5020M68SP	35 x 22	35	22	24	23
JH-5020M68SP	35 x 28	35	28	24	23



### Metric to Imperial Adaptor Ring - S68S

Code	Fitting size	A	B	C
K071020068S-	42 mm x 1-1/2"	41	11	44
S405020068S-	108 x 4"	108	29	114

All sizes are in mm unless otherwise stated

Range code:

Brass
  DZR
  Red brass

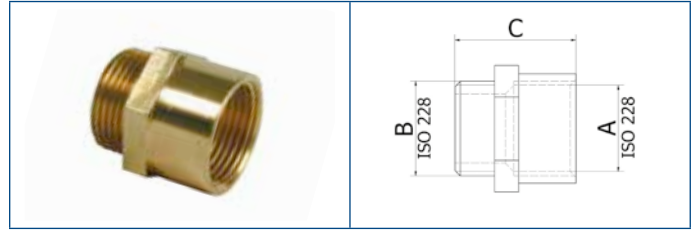

## Male to Female Adaptor - 72

Code	Fitting size	A	B	C
03-1020072--	1/2"	1/2"	1/2	22
04-1020072--	3/4"	3/4"	3/4	34



## Adaptor for Tap Extension - 74

Code	Fitting size	A	B	C	D	E
04-1020074--	3/4"	3/4"	3/4	10	11	23



## External Reducer - G68E

Code	Fitting size	A	B	C	D	E
RN-2020068E-	76 x 54	76	54	70	36	120

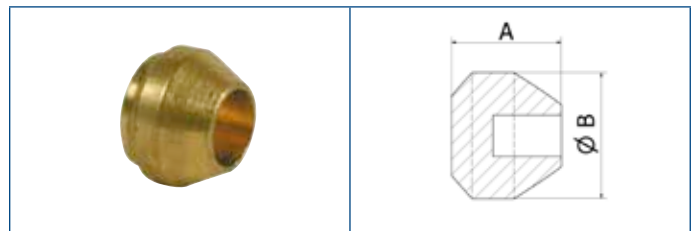

## Blank Piece - S61

Code	Fitting size	A	B
B--5020061--	8	8	11
C--5020061--	10	10	12
D--5020061--	12	12	14
E--5020061--	15	15	18
F--5020061--	18	18	20
G--5020061--	22	22.5	25
H--5020061--	28	28	32
J--5020061--	35	35	39

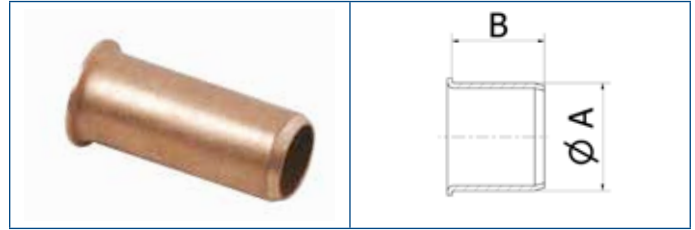

### Soft Copper Liner - SC1

Code	Fitting size	A	B
C103031000SC	10 x 1.0	9.5	7.75
D103031000SC	12 x 1.0	11.5	9.75
E103031000SC	15 x 1.0	14.5	12.75
UT-3020000SC	16 x 1.0	15.5	13.75
F103031000SC	18 x 1.0	17.5	15.75
G103031000SC	22 x 1.0	21.5	19.75
H103031000SC	28 x 0.8	27.5	28

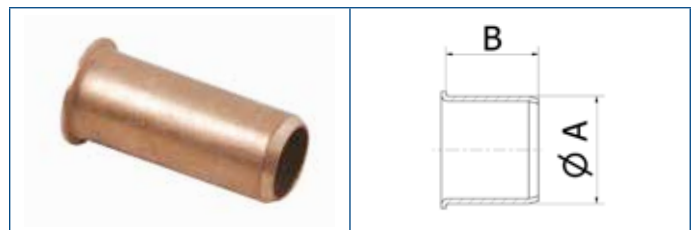

### Internal Liner - PP (PE-X / PB)

Code	Fitting size	A	B
C183031000PP	10 mm - Pe-X / PB	10	6.5
E183031000PP	15 mm - PB	15	11.2
E183031000PP	15 mm - PE-X	15	11.5
G183031000PP	22 mm - PE-X/PB	22	17.5
H293031000PP	28 mm - PE-X/PB	28	22.4

Range code:

Brass
  DZR
  Red brass

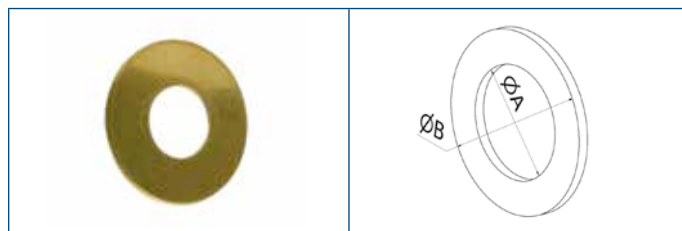

## Brass Washer - 96

Code	Fitting size	A	B
03-1020096---	1/2"	22	50
04-1020096--	3/4"	27	56
05-1020096--	1"	34	61



## Tap Sealing Washer - 97

Code	Fitting size	A	B
03-9020097--	1/2"	14.5	18.5
04-9020097--	3/4"	19.5	24

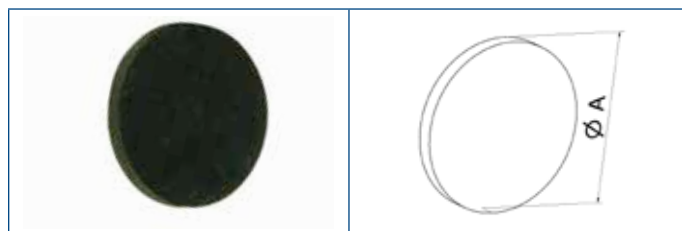

## Blank Capnut Rubber Washer - 98

Code	Fitting size	A
E--9020098--	15	18.6
G--9020098--	22	26.2
H--9020098--	28	32.5
J--9020098--	35	40
K--9020098--	42	47

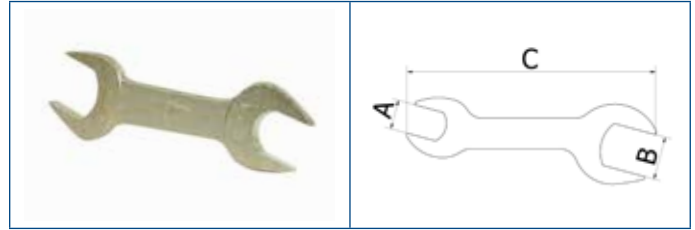

### Capnut Spanner Zinc Plated - 85

Code	Fitting size	A	B	C
GE-9520085--	22 x 15	22	15	185

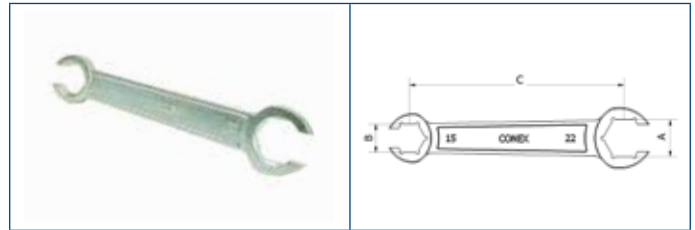

### 'C' Capnut Ring Spanner Zinc Plated - 85R

Code	Fitting size	A	B	C
GE-9020085R-	22 x 15	22	15	190

### Right to make amendments / Liability declaration

Please note that all illustrations, measurements and instructions in this document are a representation of Conex Compression fittings. These are not binding and we reserve the right to make amendments without notice. Please note technical advice is based on the current knowledge of the department at the time of creation and publication – 02/2020.

## 9.0 Guarantee

When professionally installed, used and maintained in accordance with the installation and maintenance instructions detailed in the Conex Compression Technical Brochure, Conex Universal Ltd. guarantees that Conex Compression fittings supplied by Conex Universal Ltd. will be free of material defects resulting from errors in manufacture, for twenty five (25) years from the date of first purchase by an end user. This Guarantee is limited to the repair or replacement of defective product(s) (at the sole discretion of Conex Universal Ltd.). At the request of Conex Universal Ltd. the allegedly defective product(s) must be returned to the address adjacent\* and Conex Universal Ltd. reserves the right to inspect and test the alleged defects. This guarantee provided by Conex Universal Ltd. does not affect your statutory rights.

**The guarantee set out above is given by Conex Universal Ltd. and subject to the following conditions:**

A. Any alleged defects must be reported to Conex Universal Ltd. within one month of the first occurrence of any such alleged defect, clearly setting out the nature of the claim and the circumstances surrounding it.

B. Conex Universal Ltd. shall be under no liability in respect of any defect in any product arising from:

- defective installation,
- fair wear and tear,
- wilful damage,
- negligence of any party other than Conex Universal Ltd.,
- abnormal working or environmental conditions,
- failure to follow the instructions of Conex Universal Ltd.,
- misuse (which includes any use of the product(s) concerned for a purpose or in a situation / environment or for an application other than that for which it was designed), or
- alteration or repair of any product without the prior approval of Conex Universal Ltd.

C. At the request of Conex Universal Ltd. the person claiming under this guarantee must deliver to Conex Universal Ltd. written evidence of the date of first purchase by an end user of the product(s) concerned.

**\* The address for returns is:**

Customer Services  
 Conex Universal Limited  
 Global House  
 95 Vantage Point  
 The Pensnett Estate  
 Kingswinford  
 West Midlands  
 DY6 7FT  
 UNITED KINGDOM







# Conex | Bänninger

Conex | Bänninger  
>B< Press

Conex | Bänninger  
>B< Press Gas

Conex | Bänninger  
>B< Press Solar

Conex | Bänninger  
>B< Press XL

Conex | Bänninger  
>B< Press Carbon

Conex | Bänninger  
>B< Press Inox

Conex | Bänninger  
>B< MaxiPro

Conex | Bänninger  
>B< ACR

**K65**

Conex | Bänninger  
>B< Push

Conex | Bänninger  
>B< Flex

Conex | Bänninger  
>B< Oyster

Conex | Bänninger  
>B< Sonic

Conex | Bänninger  
Triflow Solder Ring

Conex | Bänninger  
Delcop End Feed

Conex | Bänninger  
Delbraze

Conex | Bänninger  
Medical Gas

Conex | Bänninger  
Valves

Conex | Bänninger  
Conex Compression

Conex | Bänninger  
Series 3000

Conex | Bänninger  
Series 4000

Conex | Bänninger  
Series 5000

Conex | Bänninger  
Series 8000

Conex | Bänninger  
OEM



United Kingdom  
Conex Universal Limited

Germany  
IBP GmbH

Spain  
IBP Atcosa SL

France  
Conex Bänninger SRL

Italy  
IBP Bänninger Italia srl

Poland Sales, Marketing and Logistics  
IBP Instalittings Sp z.o.o.

USA  
IBP Group LLC

China  
IBP China

Tel: +49 (0)6403 7785 0 | Fax: +49 (0)6403 7785 361 | Email: [customerservicede@ibpgroup.com](mailto:customerservicede@ibpgroup.com) | [www.conexbanninger.com](http://www.conexbanninger.com)

The content of this publication is for general information only. It is the user's responsibility to determine suitability of any product for the purpose intended and reference should be made to our Technical Department if clarification is required. In the interests of technical development we reserve the right to change specification, design and materials without notice.

Conex Bänninger products are approved by numerous Standards Authorities and Certification Bodies. This is a representation of the full range from Conex Universal Ltd. IBP trademarks are registered in numerous countries.